

# Best Practices on Conveyor Safety



## ACKNOWLEDGEMENTS

Thanks are extended to all those who helped Workplace Health & Safety Policy and Legislation, Alberta Employment and Immigration, to complete the guide, *Best Practices on Conveyor Safety*. The efforts and cooperation of all involved in the preparation of this guide made its publication possible.

Special thanks to Institut de recherche Robert-Sauvé en santé et en sécurité du travail (IRSST) and Commission de la santé et de la sécurité du travail (CSST) from Quebec, for providing the French-language version of the document, *Sécurité des convoyeurs à courroie: guide de l'utilisateur*:

© Commission de la santé et de la sécurité du travail du Québec  
2e édition revue et corrigée  
Copyright Deposit – Bibliothèque nationale du Québec, 2003  
ISBN 2-550-441346-6  
DC 200-16227-1 (04-01)

The people who contributed toward production of the French version of CSST/IRSST document are: Laurent Giraud, Serge Masse, Julie Dubé, Luc Schreiber, André Turcot, Donald Duchesne, Lyne Beaulé and other members of the Comité protection des convoyeurs: Gilles Brouard, Yves Desrochers, Louise Gravel, Daniel Macleod, André Marchand, Yvon Papin, Joseph Wigorski and Gilles Gagnon.

The French-language version of the guide was translated into English with the permission of CSST. This English-language version of *Best Practices on Surveyor Safety* includes additional technical content prepared by Alberta Employment and Immigration's Technical Committee on Conveyor Safety. Additions are shown in 75% screen.

Thanks to the Industrial Accident Prevention Association (IAPA) for providing complimentary copies to the technical committee that also helped in the completion of this guide.

Thanks to the members of the Technical Committee on Conveyor Safety and all those who contributed to the completion of this guide. The contributions of the following are recognized and appreciated:

Jim Balfour, General Foreman, Processing, Elk Valley Coal  
Frankie Fuchs, CRSP, Safety Specialist, Suncor Energy  
James Gear, Safety & Environmental Coordinator, Leigh Inland Cement  
Jill M. Hofmann, Business Unit Leader, Alberta Pacific Forest Industries Inc.  
Fazal Hussain, Technical Safety Specialist, WHS Policy and Legislation, Government of Alberta  
Larry Jones, Director, Health and Safety, Alberta Forestry Product Association  
Aditya Kaura, Co-op Student (Health and Safety)  
Ashok K. Khurana, OH&S Officer, Government of Alberta  
Don McBride, Syncrude Canada Ltd.  
Trevor Milne, CHP Senior Foreman, Highvale Mine  
Muneer Naseer, Director of Mines, WHS Policy and Legislation, Government of Alberta  
Tom Shindruk, Vice President, Alberta Food Processors Association

### PROJECT MANAGER:

Muneer Naseer, P.Eng., Government of Alberta, Edmonton, AB

### TRANSLATION:

Ernest Chiasson, Les Entreprises Verret Ltée, Edmonton, AB

### PROOFREADING:

Deborah Lawson, Word Circus, Inc., Edmonton, AB

### PRINTING:

Douglas Printing, Edmonton, AB

### PUBLISHED BY:

Alberta Employment and Immigration  
Workplace Health and Safety, Policy and Legislation  
Government of Alberta

## DISCLAIMER

This material may be used, reproduced, stored or transmitted for non-commercial purposes. The source of this material must be acknowledged when publishing or issuing it to others. This material is not to be used, reproduced, stored or transmitted for commercial purposes without written permission from the Government of Alberta, Employment and Immigration. This material is to be used for information purposes only. No warranty, express or implied, is given as to the accuracy or timeliness of the material presented. In case of any inconsistency between this document and the Occupational Health and Safety legislation, the legislation will always prevail.

# TABLE OF CONTENTS

**Introduction 7**

**Scope 7**

## SECTION I GENERAL INFORMATION

**1 Overview 9**

**2 Definitions 10**

**3 Components of a Conveyor 10**

**4 Hazards 15**

**5 Hazard Assessment 18**

## SECTION II SAFEGUARDS AGAINST HAZARDS

**1 Hazard Assessment and Reduction 19**

**2 Safeguards Against Mechanical Hazards 21**

**2.1 General principles 21**

**2.2 Guards 21**

2.2.1 Allowable dimensions for guard openings

2.2.2 Fixed guards

2.2.2.1 Surrounding fixed guards

2.2.2.2 Barrier guards

2.2.2.3 In-running nip fixed guards

2.2.3 Interlocking guards

2.2.4 Interlocked guard with guard locking

**2.3 Deterrent devices 31**

**2.4 Service ways and throughways 32**

**2.5 Falling or projecting objects 32**

2.5.1 Conveyor elements

2.5.2 Carried loads

**2.6 Conveyor belt operating conditions – safety requirements 33**

2.6.1 Power transmission moving parts

2.6.2 Belts

2.6.3 Conveyor belts in a straight run

2.6.4 Curved zone

2.6.5 Transition zone

2.6.6 Drums

2.6.7 Moving loads

2.6.8 Moving sub-assemblies

2.6.9 Moveable Conveyors

<b>3</b>	<b>Safeguards Against Other Hazards</b>	<b>55</b>
3.1	Hazards generated by poor ergonomic design	55
3.2	Heat-related hazards	55
3.3	Electrical hazards	55
3.4	Fire and explosion hazards	55
3.5	Inappropriate personal protective equipment and unsafe acts	55
<b>4</b>	<b>Safeguards Against Control System Failures or Malfunctions</b>	<b>56</b>
4.1	Start-up	56
4.2	Regular stop	56
4.3	Emergency stop device	56
4.4	Emergency stop pull-cords	58
<b>5</b>	<b>Safeguards While Performing Maintenance</b>	<b>58</b>
5.1	General principles	58
5.2	Lockout (controlling hazardous energy) procedures	59
5.3	Safeguards for maintenance within operating danger zones	59
<b>6</b>	<b>Worker Training</b>	<b>62</b>
6.1	Worker training	62
6.2	Maintenance crew training	62

## APPENDICES

<b>Appendix A</b>	Guard Design	<b>63</b>
<b>Appendix B</b>	Calculating the Required Distances for Fixed Barrier Guards	<b>65</b>
<b>Appendix C</b>	Alberta Legislation Reference	<b>73</b>
<b>Appendix D</b>	Conveyor System Safety Checklist	<b>74</b>
<b>Appendix E</b>	Conveyor-Related Incidents in Alberta	<b>76</b>

## REFERENCES

<b>References</b>	<b>77</b>
-------------------	-----------

## BIBLIOGRAPHY

<b>Bibliography</b>	<b>79</b>
---------------------	-----------

## LIST OF TABLES

Table 2-1	Allowable Dimensions for Open Guards	23
Table 2-2	Required Distances for Fixed Barrier Guards	27
Table 2-3	Minimum Lengths of In-Running Nip Fixed Guards	29
Table 2-4	Safeguards for Maintenance Activities	60
Table B-1	Safety Distances	70
Table B-2	Safety Distances Through Regular Openings	71
Table C-1	Applicable Alberta Legislation	73
Table E-1	Conveyor-Related Incidents in Alberta	76

## LIST OF FIGURES

Figure 1-1	Diagram of belt conveyor	11
Figure 1-2	Types of belt supports	12
Figure 1-3	Typical bulk loading system	13
Figure 1-4	Impact systems	14
Figure 1-5	Typical power transmission moving-parts hazards	15
Figure 1-6	Typical mechanical hazards	16
Figure 1-7	Typical hazards of individual loads and fixed obstacles	17
Figure 1-8	Typical hazards of moving sub-assemblies	17
Figure 2-1	Hazard assessment and reduction flow chart	20
Figure 2-2	Typical surrounding fixed guard (partial cage)	24
Figure 2-3	Surrounding barrier guard for load bearing rollers and return rollers	25
Figure 2-4	Curved zone surrounded by fixed guard	25
Figure 2-5	Typical surrounding fixed guards (side screens with no protection underneath)	26
Figure 2-6	Typical barrier guard (danger zone is at least 100 mm from the guard)	26
Figure 2-7	Illustration for Table 2-2	27
Figure 2-8	In-running nip fixed guard (form-fitting element)	28
Figure 2-9	In-running nip fixed guard (angled deflector with side plates)	28
Figure 2-10	Operating principle of interlocking guards	30
Figure 2-11	Operating principle of interlocked guard with guard locking	30
Figure 2-12	Typical deterrent devices	31
Figure 2-13	Surrounding fixed guard for pulleys and power transmission	33
Figure 2-14	Surrounding fixed guard for couplings	33
Figure 2-15	Surrounding fixed guard for shafts	33
Figure 2-16	Surrounding fixed guard for shaft ends	33
Figure 2-17	Typical protective measures for throughways	34
Figure 2-18	Mechanical splices	35
Figure 2-19	Surrounding fixed guard in loading area	36

Figure 2-20	In-running nip fixed guard for support rollers (plates)	37
Figure 2-21	Surrounding fixed guard for support rollers	37
Figure 2-22	Surrounding fixed guard for return rollers	38
Figure 2-23	In-running nip fixed guards for return rollers	38
Figure 2-24	Typical protective devices for throughways	39
Figure 2-25	Deterrent device (side plate) for return rollers located less than 700 mm from the floor	40
Figure 2-26	Return roller retaining device	41
Figure 2-27	Surrounding barrier guard for drum and scraper (partial cage)	42
Figure 2-28	Surrounding fixed guards for curved zone	43
Figure 2-29	Curved zone in-running nip guard	43
Figure 2-30	Protectors for head drum and transition zone	44
Figure 2-31	In-running nip guard for drum	45
Figure 2-32	Scrapers serving as an in-running nip guard	45
Figure 2-33	Surrounding fixed guard for tail drum	46
Figure 2-34	Barrier guard for gravity-type tensioner	47
Figure 2-35	Fixed guard at conveyor belt junction	48
Figure 2-36	Pop-up rollers at conveyor belt junction	48
Figure 2-37	Typical protective measures against hazards associated with individual loads and fixed obstacles	50
Figure 2-38	Typical guard for individual loads and rollers exceeding belt width	51
Figure 2-39	Typical protective devices for throughways	52
Figure 2-40	Typical barriers for ejectors	53
Figure 2-41	Moveable conveyor	54
Figure 2-42	Standard symbol designating forced to break contact devices	57
Figure A-1	Typical hinged fixed guard	63
Figure A-2	Typical quarter-turn keyed spring latch	64
Figure A-3	Captive fasteners	64
Figure B-1	Separation barrier guard – Example 1	66
Figure B-2	Separation barrier guard – Example 2	68
Figure B-3	Safety distances for openings of irregular shape	72

# INTRODUCTION

Each year, physical contact with machines and powered equipment accounts for a significant number of life-altering injuries and fatalities. A number of these incidents involve conveyor systems. The majority of these incidents occur during maintenance activities with conveyors still in operation and danger zones unprotected.

Preventive measures should be implemented in order for work on or near conveyors to be performed safely. Right from the design stage, worker exposure to hazards should be controlled by reducing the frequency of conveyor clean-ups, conveyor maintenance, removal of jams, etc. This guide to best practices suggests possible preventive measures, but it is by no means exhaustive. In many situations, hazards must be analyzed before any preventive measures are implemented.

This guide is composed of two sections. Section I provides definitions, a general idea of conveyor components, an overview of mechanical hazards and information about hazard assessment and reduction. Section II covers safeguards against hazards during operation and maintenance of conveyor systems, and related worker training.

Appendices provide details on guard design, applicable Alberta legislation, conveyor safety checklists, inspection guidelines and an overview of conveyor-related accidents in Alberta.

The list of scientific works used in the production of the original French-language version, namely a number of Canadian, European and/or international standards, regulations and best practice guidelines, is presented in the Bibliography. As well, a References section provides sources for information on conveyors and machine safety.

The guide is intended to be used as a best practices reference document for safety around conveyor systems. It is directed mainly to workers, technicians, supervisors, joint health and safety committee members and other interested parties.

This guide references the Alberta Occupational Health and Safety (OH&S) legislation of 2009. If any conflicts are found between this guide and the legislation, the current legislation will always prevail.

# SCOPE

This document is intended to serve as a guide for identifying best practices including conveyor guarding, hazardous energy isolation and visual inspection procedures for industries that utilize belt conveyor systems in Alberta.

Note: Design, maintenance and repair of conveyor systems are not within the scope of this guide.

The background is a monochromatic blue image. In the lower half, a handprint is visible on a grid pattern, with a fingerprint scanner positioned to its right. The overall aesthetic is technical and digital.

SECTION I  
GENERAL INFORMATION



# SECTION I GENERAL INFORMATION

## 1 OVERVIEW

The main characteristics of belt conveyors from the safety standpoint are:

- ▶ a belt that may vary greatly in length—conveyors may be from a few meters to several kilometres long and may be split into smaller length or sections
- ▶ the fact that the majority of accidents occur in the areas of head drums, tail drums and drive mechanisms
- ▶ the fact that the majority of accidents occur during cleaning or other maintenance activities
- ▶ the existence of hazards related to:
  - ▶ power transmission moving parts (motor parts, transmission parts, gears, etc.)
  - ▶ moving loads
  - ▶ moving sub-assemblies (switch mechanisms, pushers, etc.)
  - ▶ proximity to unrestricted access throughways and throughways passing over or under equipment
  - ▶ conflicts between repeated stoppages (to clear jams) and production requirements
  - ▶ stoppages from causes unknown to operators and other workers not located near the conveyor, resulting in situations that may lead to dangerous actions
  - ▶ falling loads
  - ▶ the performance of work on equipment that is not isolated from hazardous energy
- ▶ the existence of varying degrees of risk depending upon the conveyor belt's dimensions and the load size (mass) and speed
- ▶ hazards posed by a particular mechanism or by an entire conveyor zone

## 2

## DEFINITIONS

**danger zone:** Any area inside or around equipment that presents a hazard to a worker's health, safety or physical integrity.

**intervention area:** The area in and around equipment and the moving load, including access points and integrated access ways.

**loading and unloading zones:** Areas where loads are picked up or deposited, either manually or automatically, after conveyance.

**maintenance tasks:** Inspection, cleaning, unclogging, load un-jamming, greasing, adjustments, repairs or other maintenance.

**production operations tasks:** Start-up, shut-down and other operations such as loading and unloading, assembly, fastening, labelling, coding, monitoring, etc.

**service way:** An area around conveyor(s) reserved for access to equipment for operation and maintenance.

**work area:** A place at a work site where a worker is, or may be, present during work or during a work break.

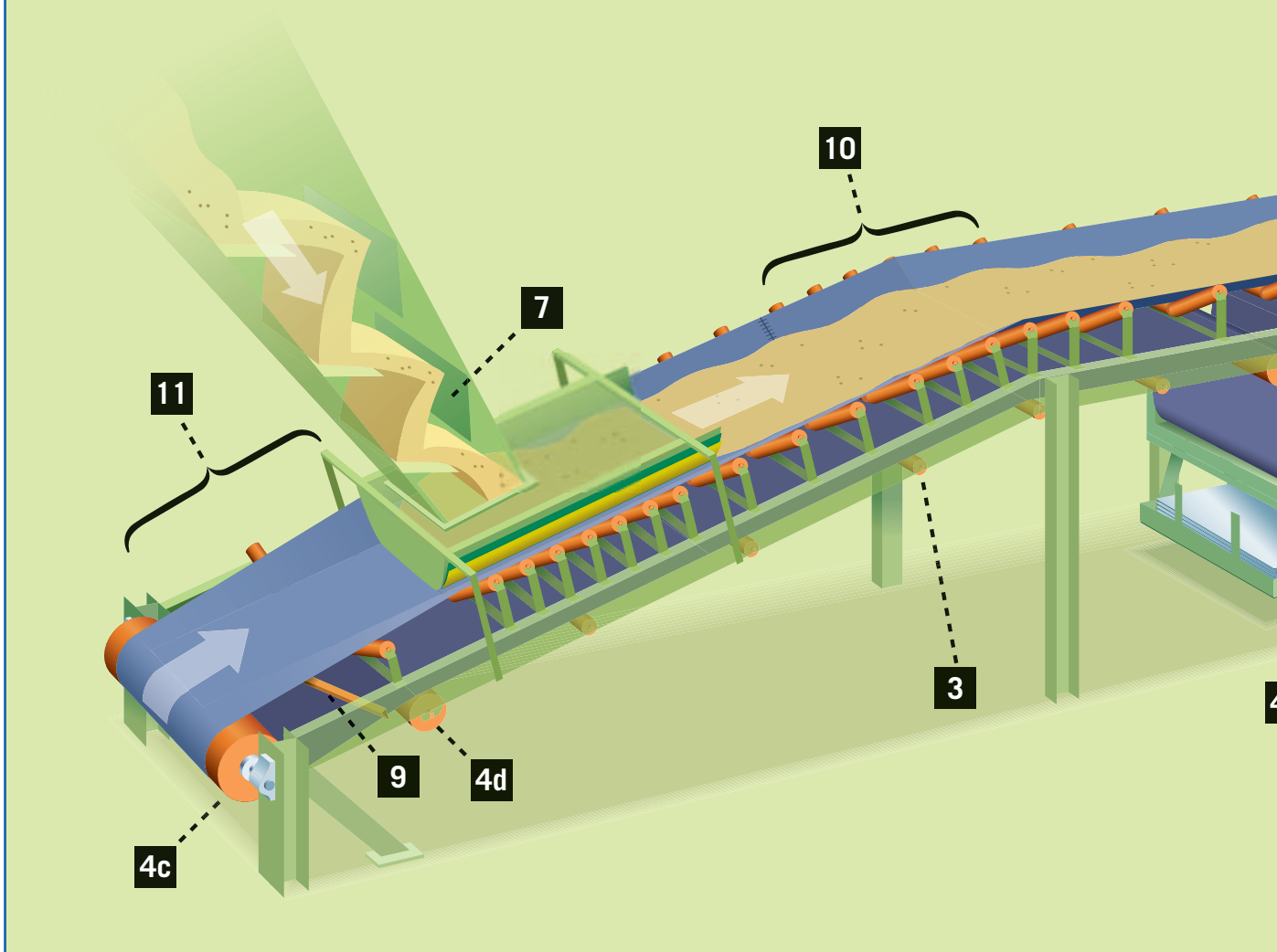
**worker:** A competent person, or a person directly supervised by a competent person, who operates, repairs and/or maintains the machinery or equipment used in a facility.

## 3

## COMPONENTS OF A CONVEYOR

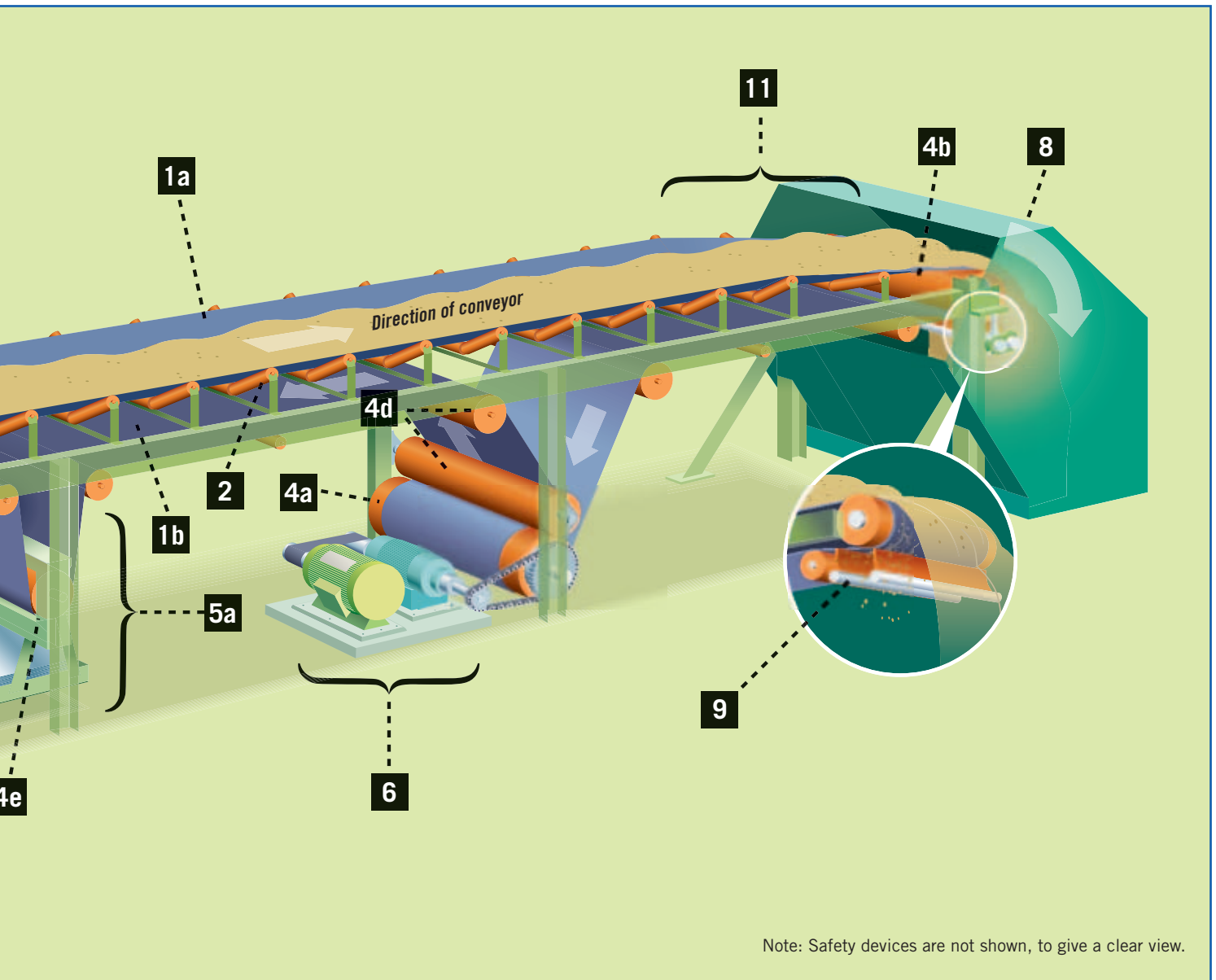
The principal conveyor components are defined below and illustrated in Figures 1-1 to 1-3. The numbers in the Figures correspond to the numbers in the legend and in the definitions that follow.

*Bulk Loading*

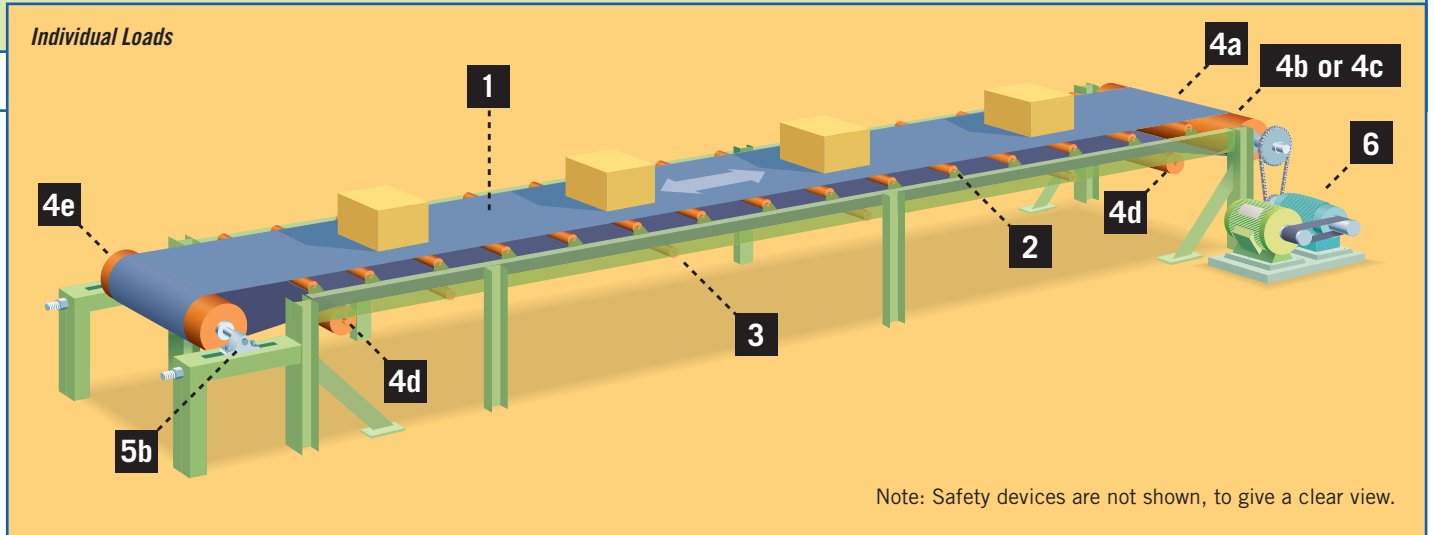


**FIGURE 1-1** DIAGRAM OF BELT CONVEYOR

- |                        |                                       |                                    |
|------------------------|---------------------------------------|------------------------------------|
| 1 BELT                 | 5 TAKE UP SYSTEM                      | 9 BELT AND DRUM<br>CLEANING SYSTEM |
| 1a Load Strand         | 5a Gravity System                     | 10 CURVED ZONE                     |
| 1b Return Strand       | 5b Manual or Self-Adjusting<br>System | 11 TRANSITION ZONE                 |
| 2 LOAD BEARING ROLLERS | 6 POWER TRANSMISSION<br>MOVING PARTS  |                                    |
| 3 RETURN ROLLERS       | 7 LOADING SYSTEM                      |                                    |
| 4 DRUMS (PULLEY)       | 8 UNLOADING SYSTEM                    |                                    |
| 4a Drive Drum          |                                       |                                    |
| 4b Head Drum           |                                       |                                    |
| 4c Tail Drum           |                                       |                                    |
| 4d Snub Drum           |                                       |                                    |
| 4e Tensioning Drum     |                                       |                                    |



Note: Safety devices are not shown, to give a clear view.



Note: Safety devices are not shown, to give a clear view.

## 1 BELTS

Belts convey or transport material:

**1a** load (upper) strand

**1b** return (lower) strand

## 2 LOAD BEARING ROLLERS

Load bearing rollers support the belt and reduce its resistance to movement of the load. Some load carrying rollers may also be impact-reducing, self-aligning or trough forming (see Figure 1-2), or may be able to change the inclination of the belt.

## 3 RETURN ROLLERS

Return rollers support the belt and reduce resistance to movement. Some return rollers may also be self-aligning or may be able to change the inclination of the belt.

## 4 DRUMS (PULLEYS)

Drums drive a belt or re-orient the direction of travel. Types of drums include:

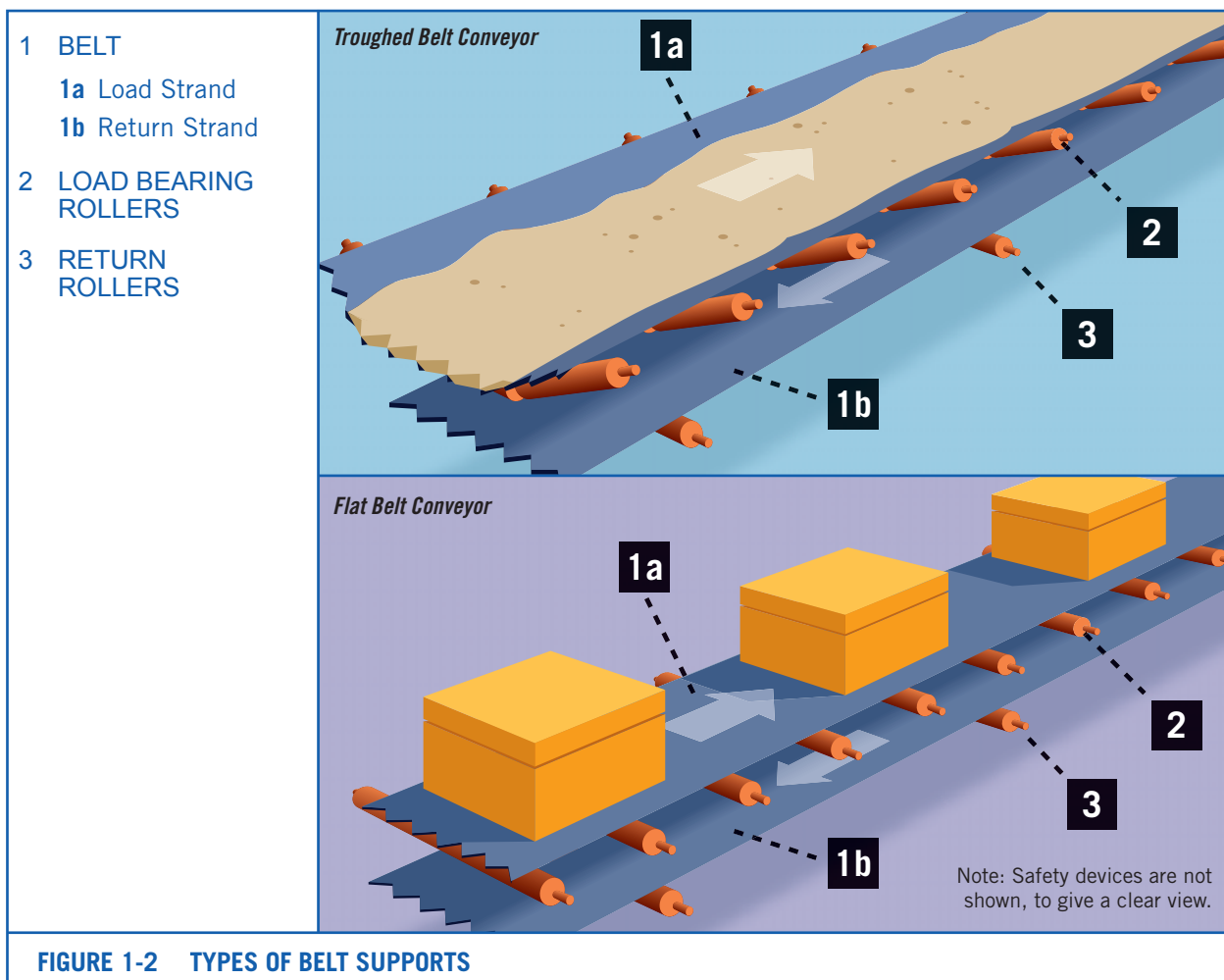
**4a** drive drum – drives the belt by being itself driven by a motor

**4b** head drum – returns the belt to the lower strand (and may also serve as a drive drum)

**4c** tail drum – returns the belt to the upper strand

**4d** snub drum – aligns the entering or exiting strand with the lower strand or ensures the required arc of contact with the drive drum

**4e** tensioning drum – maintains proper belt tension by way of a take-up system



## 5 TAKE-UP SYSTEMS

Take-up systems ensure proper belt tension. Types of systems include:

- 5a** gravity system – a guided weight pulls the tensioning drum (see Figure 1-1, also 4e, above) to provide the tension
- 5b** manual or self-adjusting system – adjustment screws or automatic control systems provide the required tension

## 6 POWER TRANSMISSION MOVING PARTS

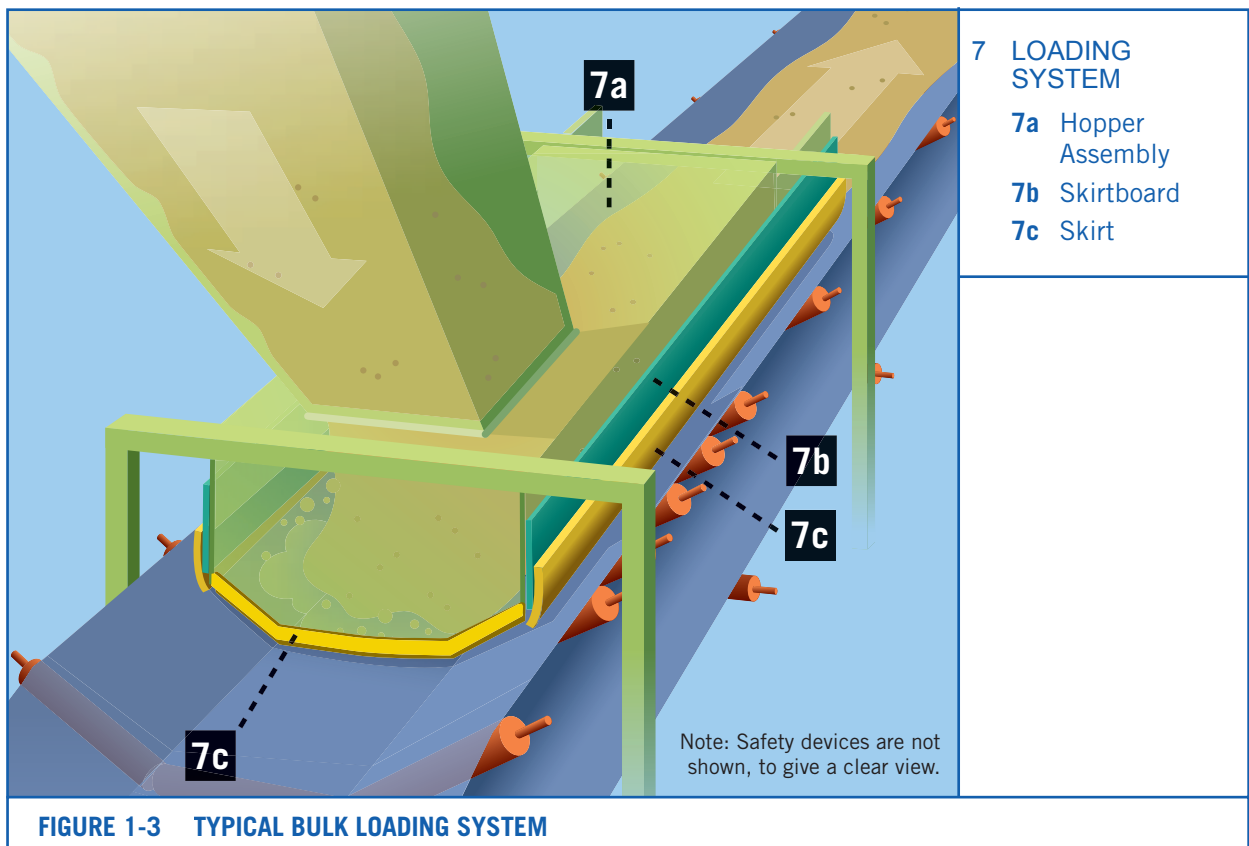
Power transmission moving parts produce and transmit the required energy to the drive drum for moving or restraining the belt. Many combinations are possible:

- ▶ a geared motor may be mounted directly to the drive drum shaft or integrated into the drive drum
- ▶ the motor and speed-reducing units may be connected by couplings
- ▶ chains, belts or couplings may be used between the motor and the drive drum shaft

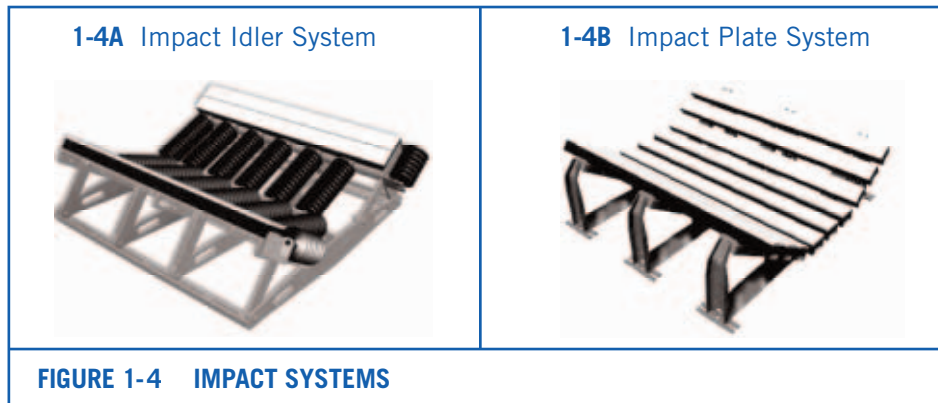
## 7 LOADING SYSTEMS

Loading systems guide and control the load feed on the belt (see Figure 1-3). There are many possible systems, including hoppers, chutes, automatic loaders, pushers, etc. Hoppers usually contain the following parts:

- 7a** hopper assembly – guides, contains and sometimes controls the bulk load feed
- 7b** skirtboard – centers the load on the belt or redirects the load; the skirt (7c) is bolted onto it
- 7c** skirt – stops loose material from leaking off the belt
- 7d** impact systems – impact systems/plates are put on a conveyor system below the feed hopper to ensure the belt does not sag from the excess weight and cause spillage



Two types of impact systems, plate and idler, are shown below (see Figures 1-4A and 1-4B). Impact plate systems take the place of impact idlers under a feed chute, to absorb the impact of material and create a dust seal.



## 8 UNLOADING SYSTEMS

Unloading systems guide the load exiting the conveyor system. Various devices may be used, including chutes, slides, automated systems, ejectors, packagers, etc.

## 9 BELT AND DRUM CLEANING SYSTEMS

Belt and drum cleaning systems remove material accumulation from belts and drums. These are often scrapers and brushes.

A scraper that is working properly can:

- ▶ save many hours of cleanup, thus increasing efficiency
- ▶ reduce possible damage to the belt from buildup underneath
- ▶ reduce worker exposure to hazards

## 10 CURVED ZONE

The curved zone is the area of the conveyor where the belt is vertically curved.

## 11 TRANSITION ZONE

The transition zone is the conveyor area where the profile (cross) of the belt changes from troughed to flattened and vice versa.

## 12 SHUNTING MECHANISMS

Shunting mechanisms change load direction. Various devices may be used, including bumpers, pushers, ejectors, etc. (see Figure 1-8).

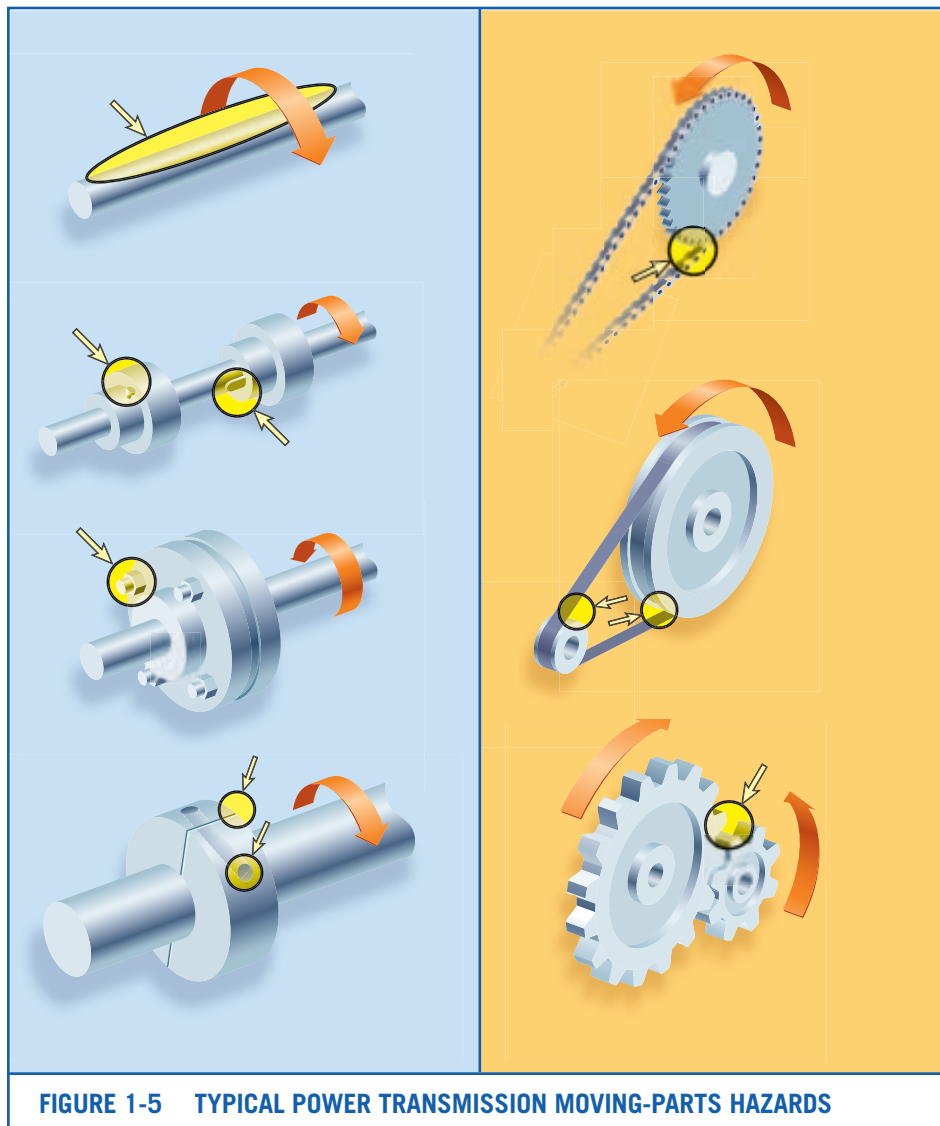
# 4

## HAZARDS

Hazards associated with conveyors are principally mechanical in nature. They are discussed briefly below.

Other hazards are covered in Section II of this guide. They are hazards generated by neglecting ergonomic principles in machine design, or by breakdown-related or security-related control system malfunctions, electricity, heat, fire or explosions.

- ▶ **Power transmission moving-part hazards:** These hazards are associated mainly with the power transmission parts between the motor and the drive (live) drum. They include shafts, couplings, pulleys and drive belts, chains and sprockets (see Figure 1-5). Dragging, crushing or entanglement on contact with rotating parts or pinch points can result in serious injuries.

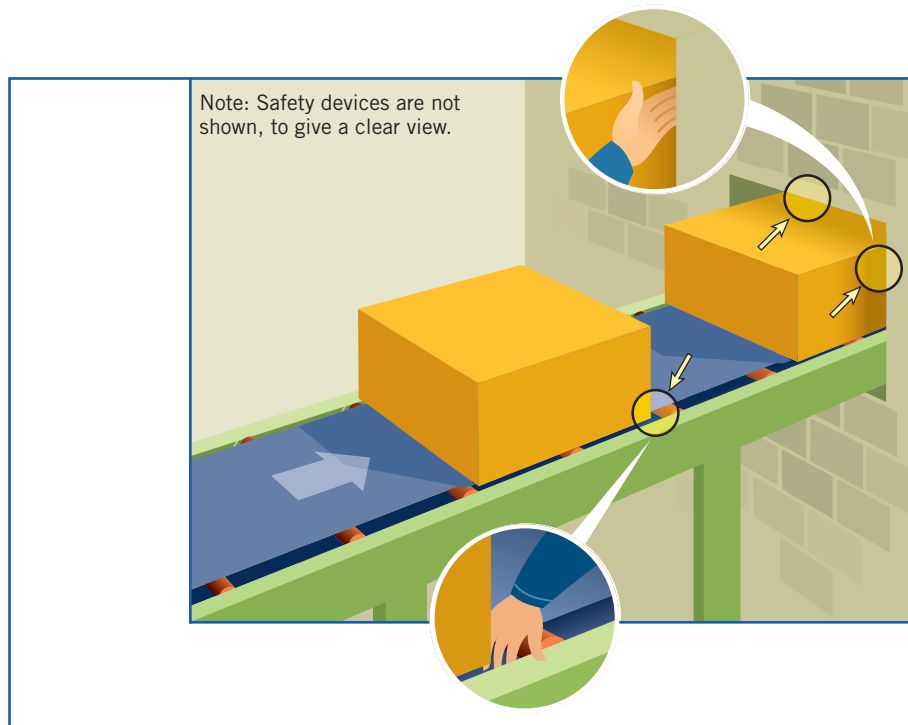




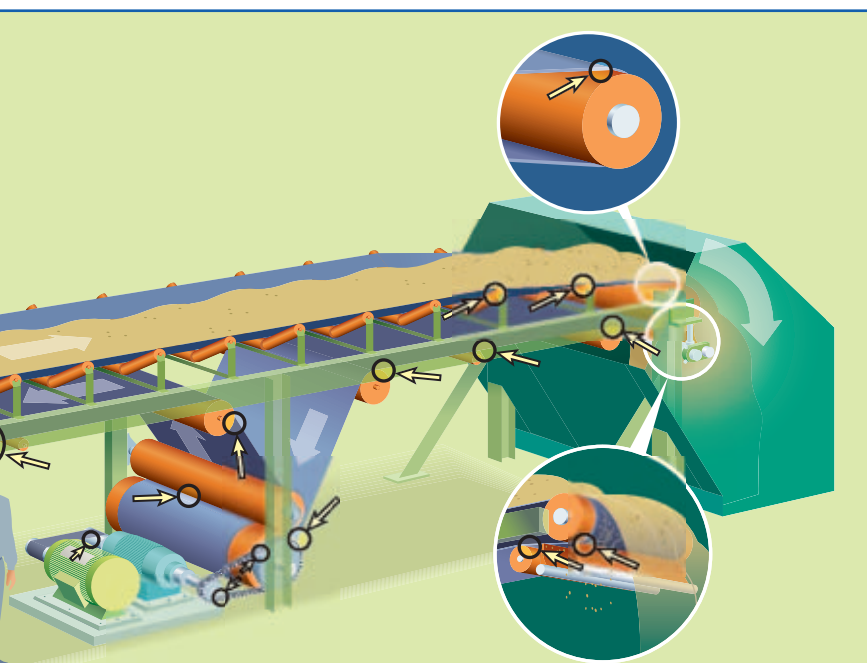
- ▶ **Hazards associated with other moving parts of a conveyor:** These are associated with the moving conveyor belt and in-running nips when in contact with rollers and drums, and to falling return rollers dislodged from worn fasteners. These hazards can result in injuries to a worker from being dragged into in-running nips, or in abrasion and friction burns from rubbing against the belt, or in injuries from being struck by a ruptured belt or a falling roller (see Figure 1-6).
- ▶ **Confinement area hazards:** Injuries result from shearing and crushing between the load, the conveyor belt and a fixed object, for example, hopper, skirtboard or skirting (see Figure 1-6).
- ▶ **Moving-load hazards:** Injuries result from shearing and crushing between the load and a fixed object. Injuries can also be caused by falling loads or impacts with loads (see Figure 1-7).
- ▶ **Moving sub-assembly hazards:** Injuries result from shearing and crushing between the load and a fixed object, and occur mainly with equipment that re-orientates the load (see Figure 1-8).



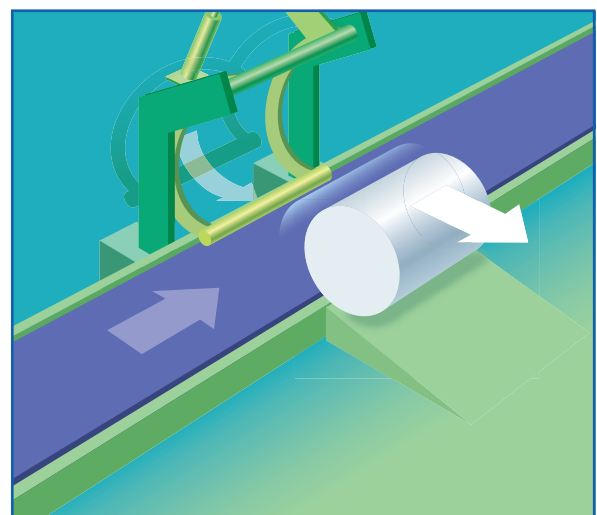
FIGURE 1-6 TYPICAL MECHANICAL HAZARDS



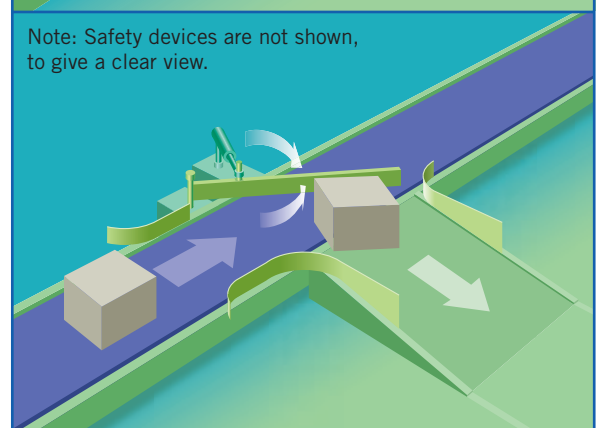
**FIGURE 1-7 TYPICAL HAZARDS OF INDIVIDUAL LOADS AND FIXED OBSTACLES**



Note: Safety devices are not shown, to give a clear view.



Note: Safety devices are not shown, to give a clear view.



**FIGURE 1-8 TYPICAL HAZARDS OF MOVING SUB-ASSEMBLIES**

# 5

## HAZARD ASSESSMENT

Once hazards have been identified they must be eliminated or controlled by applying and implementing appropriate safeguards and other control measures. It is necessary to carry out a hazard assessment to determine which hazards to address first, and to determine the most effective methods of controlling them. A flow chart for doing a hazard assessment and a detailed explanation of the process appear in Section II of this guide.

## 1

## HAZARD ASSESSMENT AND REDUCTION

The diagram in Figure 2-1 illustrates an ongoing process for hazard assessment and reduction. The following guidelines will be helpful in hazard assessment, elimination and control:

- a) Hazard assessment must be done to identify existing and potential hazards.
- b) Identified hazards must be eliminated or reduced.
- c) The hazard assessment process must be documented and, should any changes in process occur, repeated.
- d) Workers must be informed of all hazards, and all affected workers must be involved in assessment, elimination and control of hazards identified.
- e) For each hazard that cannot be eliminated or reduced by engineering or administrative controls, safeguards or protective devices must be installed.

**Note:** The Alberta Occupational Health and Safety Code (OH&S Code) details the requirements of Hazard Assessment, Elimination and Control, in Part 2 of the Code. These regulations must be followed in order to meet legislative requirements.

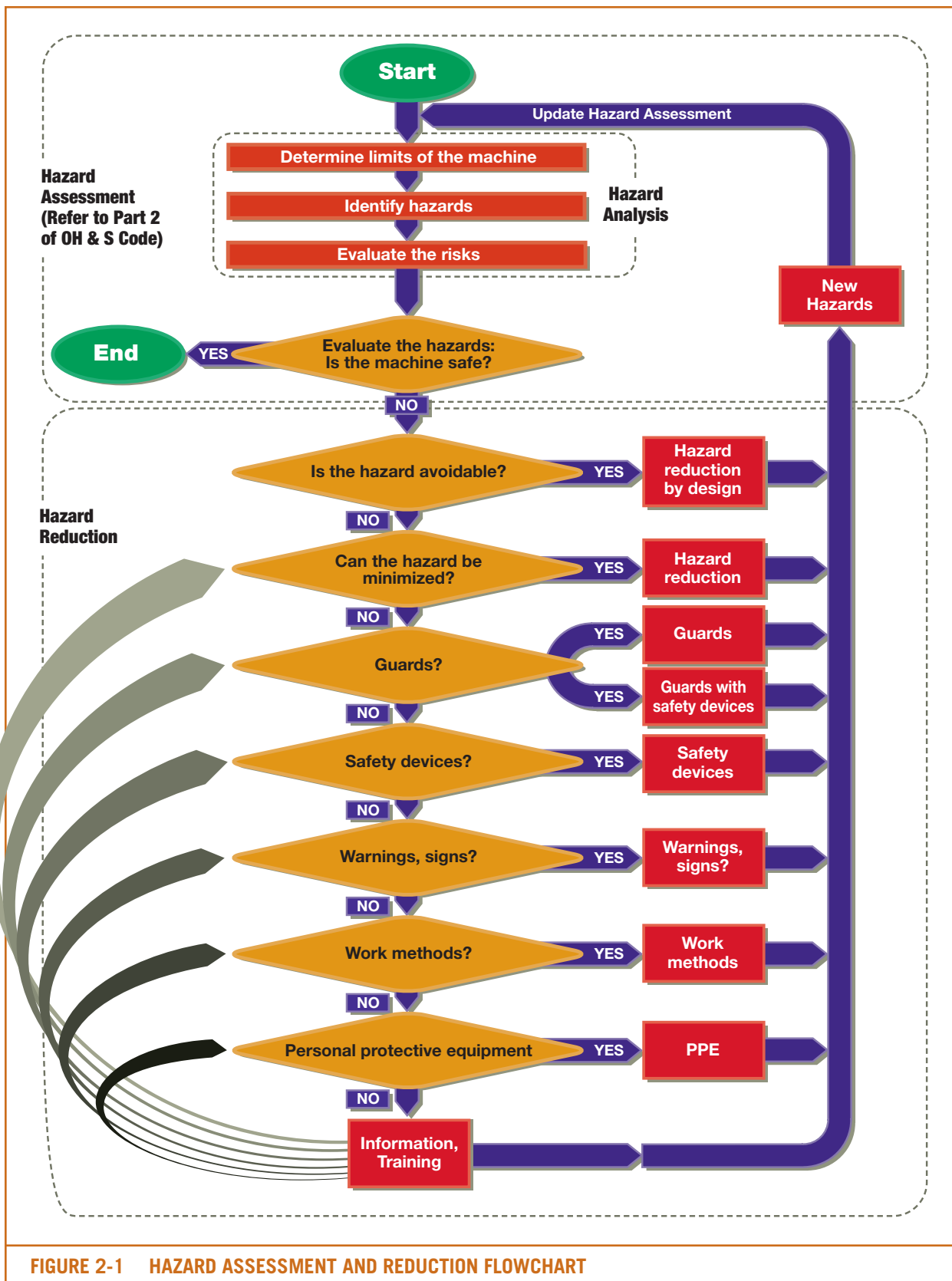


FIGURE 2-1 HAZARD ASSESSMENT AND REDUCTION FLOWCHART

## SAFEGUARDS AGAINST MECHANICAL HAZARDS

### 2.1 General principles

Many danger zones (as defined in Part 22, Section 310 of the OH&S Code) exist in and around conveyor belts. Hazards are located in these danger zones. Section 310 of the Code describes provisions relating to the installation of guards and protective devices on machines.

Refer to Part 36 of the OH&S Code, for safety devices that could be installed on conveyor systems. CAN/CSA Z432-04, Safeguarding of Machinery, specifies general features of safety devices and guards. According to the OH&S Code, a conveyor must be constructed in such a way as to not allow access to danger zones or, by default, must be equipped with guards and protective devices. Deterrent devices may also be used.

Various types of conveyor belt protectors and deterrent devices, as well as safety requirements for conveyor sub-assemblies, are described below.

Preventive measures for hazards related to conveyor operation must be implemented when a hazard is 2700 mm or less from the floor or working platform.

### 2.2 Guards

A guard is a machine element that makes the danger zone inaccessible by isolating it. Guards on conveyor belts are required to be designed with operating conditions in mind. They should be capable of resisting the loads to which they will be subjected. These devices must not create additional hazards or tempt workers to bypass their use. The dimensions and weight of movable guard components should be designed to allow for easy handling. To this end, it is preferable to have articulated or hinged guards. Guard removal and reinstallation should be quick and easy. Ideally, guards should be self-locking when closed. For more information on user-related characteristics (color, ease of manipulation, etc.) and guard construction, see Appendix A of this guide.

There are three types of guards:

1. fixed guards
  - ▶ surrounding fixed guards
  - ▶ barrier guards (fixed distance)
  - ▶ in-running nip fixed guards
2. interlocking guards
3. interlocked guards with guard locking

## 2.2.1 Allowable dimensions for guard openings

A guard can have openings. The specifications for the allowable dimensions for the guard openings in Table 2-1 are taken from CAN/CSA Z432-04, Safeguarding of Machinery.

Guard opening dimensions can be verified with a tool called a safety ruler (see Table 2-1). This tool makes it possible to check whether the hazard can be reached through the guard.

## 2.2.2 Fixed guards

A fixed guard is a permanent part of the machine. It is not dependent upon moving parts to perform its intended function. It may be constructed of sheet metal, screen, wire cloth, bars, plastic, or any other material substantial enough to withstand whatever impact it may receive, and to endure prolonged use. A fixed guard is usually preferable to all other types because of its permanence and relative simplicity.

Guards may be easily opened with tools or keys, for instance when equipped with quarter-turn latches. When keyed latches are used, responsibility for controlling and distributing socket keys or tools must be assigned.

### 2.2.2.1 Surrounding fixed guards

This is a fixed guard that either completely or partially surrounds the danger zone. (Because of openings required for belt and load passage, surrounding fixed guards may only partially surround the danger zone.)

In conveyor belts, fixed guards that only partially surround the danger zone take on two principle shapes:

- ▶ partial cages, as illustrated in Figure 2-2 and used mainly for head and return drums
- ▶ side screens, as illustrated in Figure 2-3

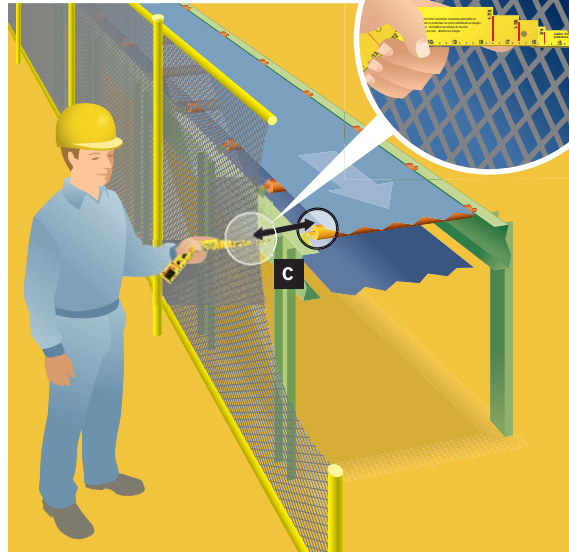
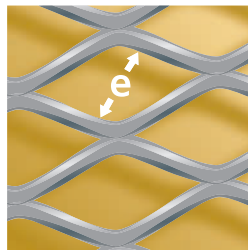
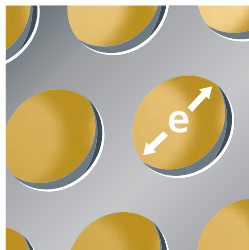
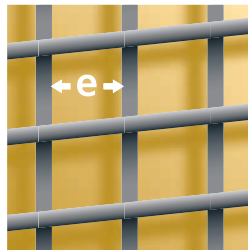
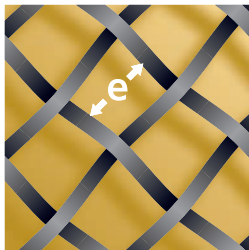
Guards must extend beyond the in-running nips between the belts and rollers so as to make them inaccessible from above, below and from the ends.

#### **To prevent access from guard ends**

- ▶ For partial cages like the one illustrated in Figure 2-2, the guard must extend 1000 mm from a drum centre.
- ▶ Side screens must extend 1000 mm from the side of the first roller (load carrying or return) or drum, at the entrance side of the belt in the protected area. On the exit side, they must extend 620 mm from the centre of a roller and 1000 mm from the centre of the drum (Figure 2-3).
- ▶ Whatever the length of the side screens or cages, in-running nips must be inaccessible at screen or cage ends, and from under the belt.

**TABLE 2-1 ALLOWABLE DIMENSIONS FOR OPEN GUARDS**

	Safe Distance <i>c</i> (mm)	Maximum Aperture Width <i>e</i> (mm)
Square	13 - 48	6
	49 - 66	11
	67 - 166	16
	167 - 445	32
	446 - 915	49
	915 or greater	132
Slotted	13 - 64	6
	65 - 89	11
	90 - 166	16
	167 - 445	32
	445 - 915	49
	915 or greater	132



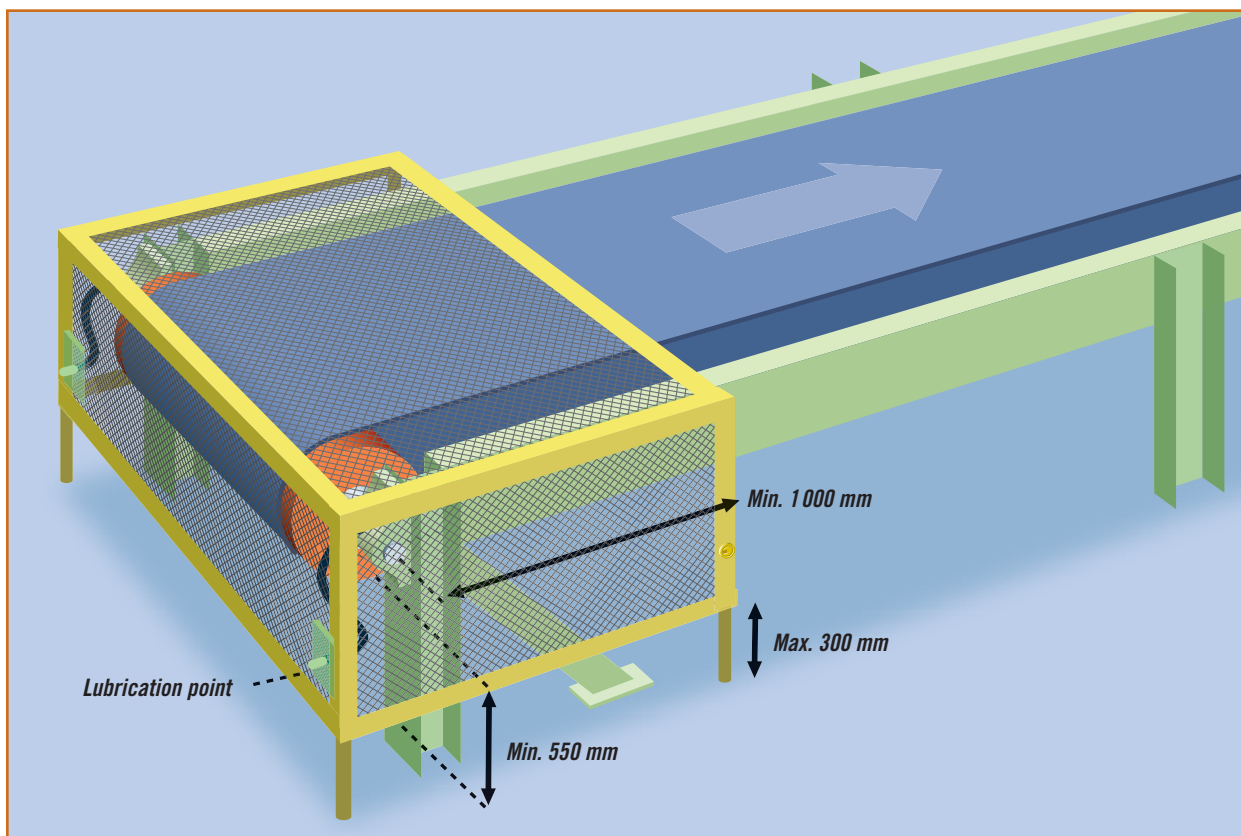
How to Measure Openings

How to Use the Safety Ruler



The Safety Ruler





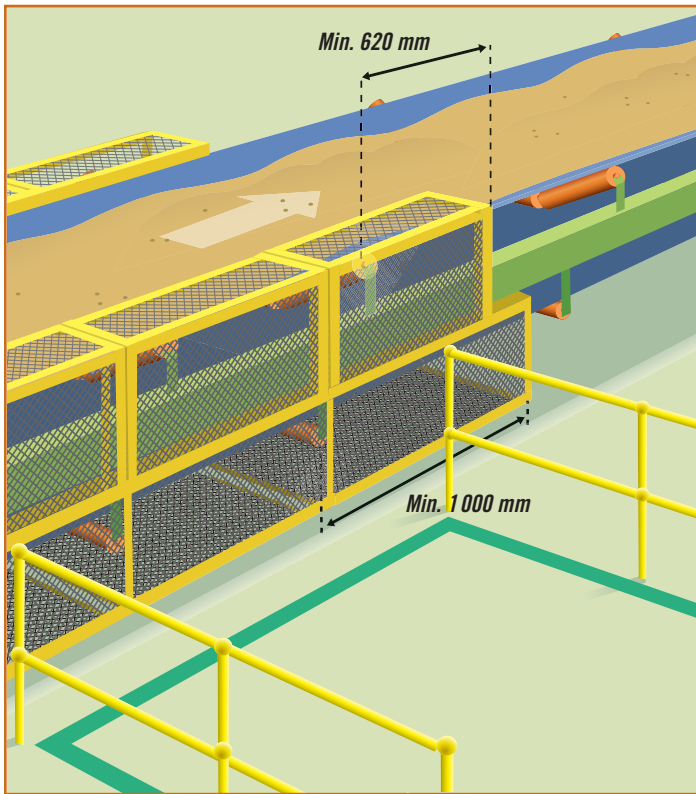
**FIGURE 2-2 TYPICAL SURROUNDING FIXED GUARD (PARTIAL CAGE)**

#### To prevent access from above the guards

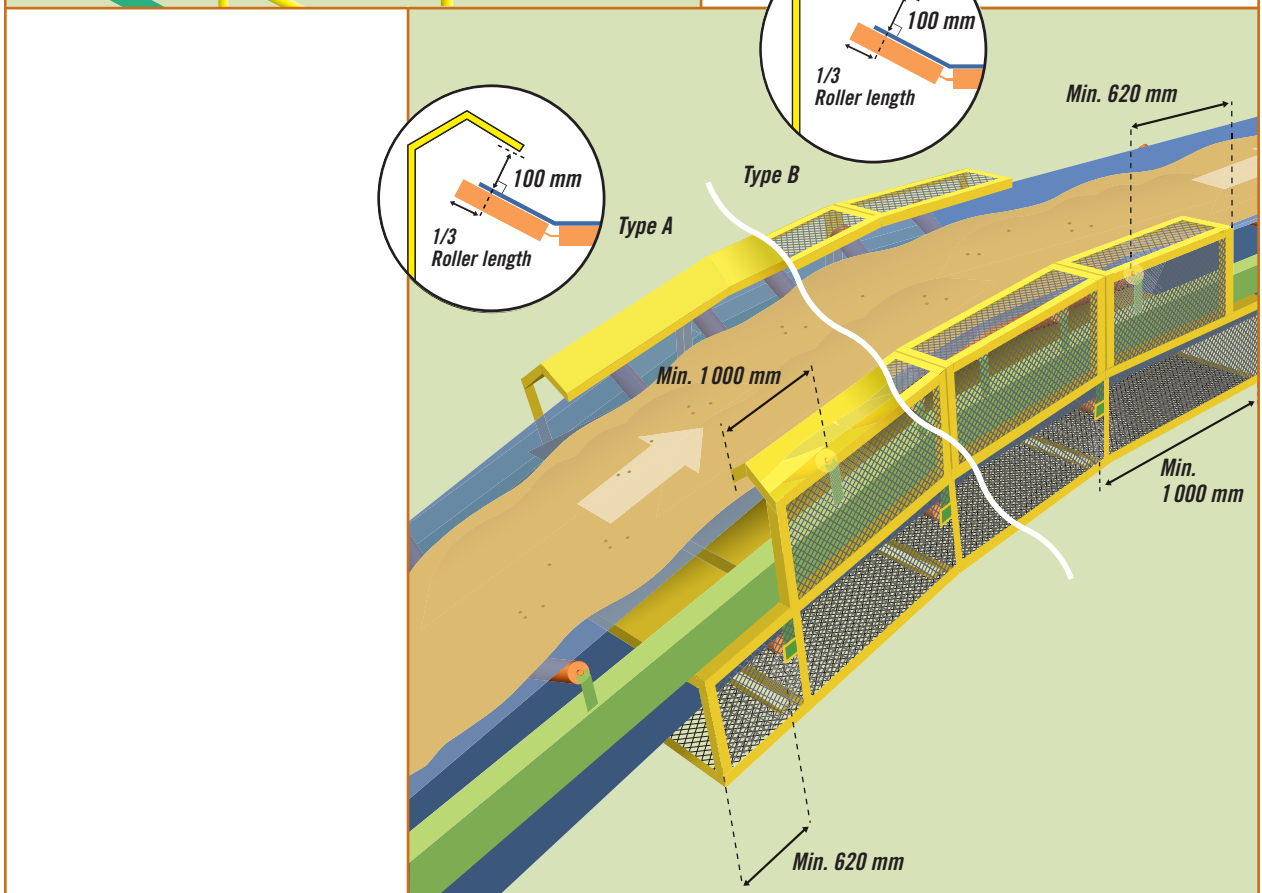
- ▶ Cages should be closed at the top.
- ▶ Side screens may take on a variety of shapes as shown in Figures 2-3 and 2-4 (screens with a 90° or other angle bend), to make in-running nips inaccessible from above the guard. The distance between the guard and the belt must be at least 100 mm to prevent a hand from getting jammed between them. For troughed conveyors, the distance, which is calculated perpendicularly from the angled roller, must be equal to one third the roller length from the roller top (see Figures 2-3 and 2-4).
- ▶ Table 2-2, which applies to the barrier guards, can be used to determine the height of the upright screens.

#### To prevent access from under the conveyor

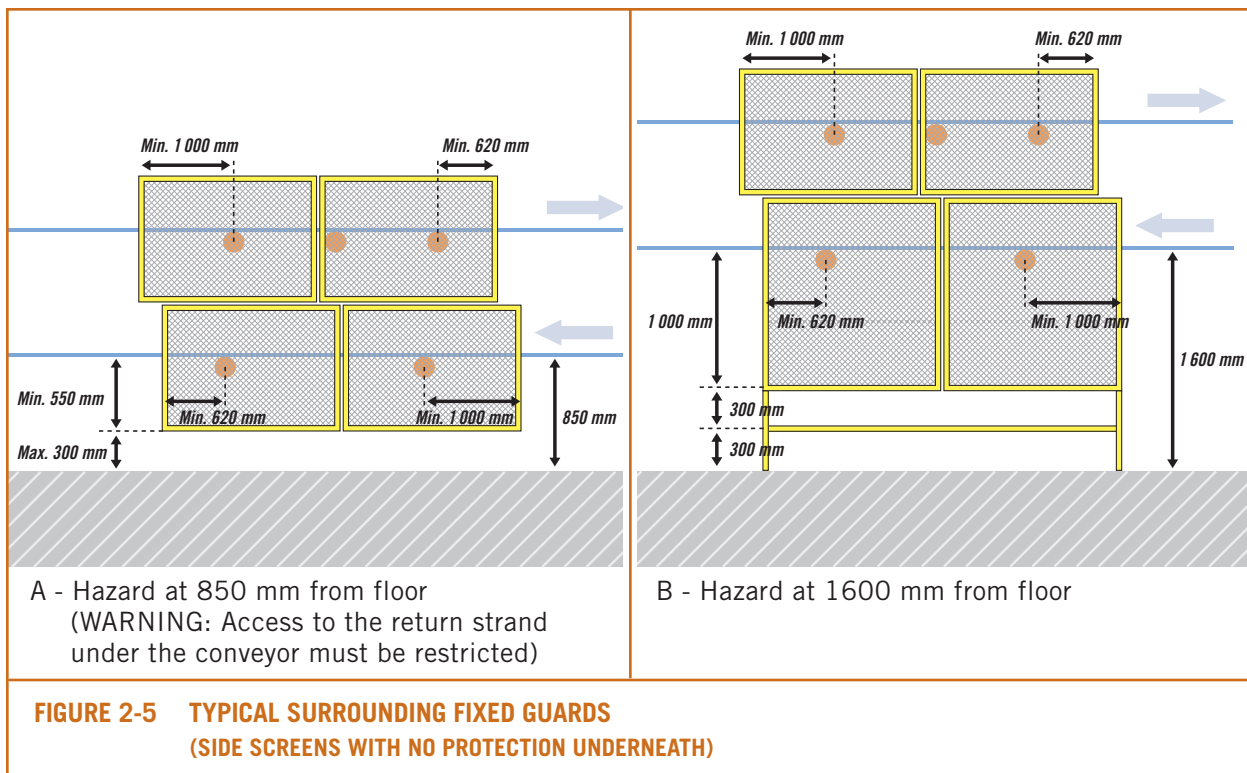
- ▶ Under-conveyor access can be prevented by a screen such as the one illustrated in Figure 2-3.
- ▶ Where there is no access-restricting screen under a conveyor, side screens must extend 1000 mm below the roller and belt in-running nips.
- ▶ When in-running nips are 1000 mm or less from a floor, the guard must extend to the floor. For housekeeping purposes, a 300 mm opening may be allowed under the guard provided it extends 550 mm or more under a pinch point from which it was designed to restrict access (see Figures 2-2, 2-5(A) and 2-33). If the distance of 550 mm cannot be maintained, the opening under the guard must meet the specifications in Table 2-1.
- ▶ When in-running nips are more than 1000 mm from the floor, openings under the guard must not exceed 300 mm. Bars like those illustrated in Figure 2-5(B) may be used to lock these openings.



**FIGURE 2-3 SURROUNDING BARRIER GUARD FOR LOAD BEARING ROLLERS AND RETURN ROLLERS**



**FIGURE 2-4 CURVED ZONE SURROUNDED BY FIXED GUARD**

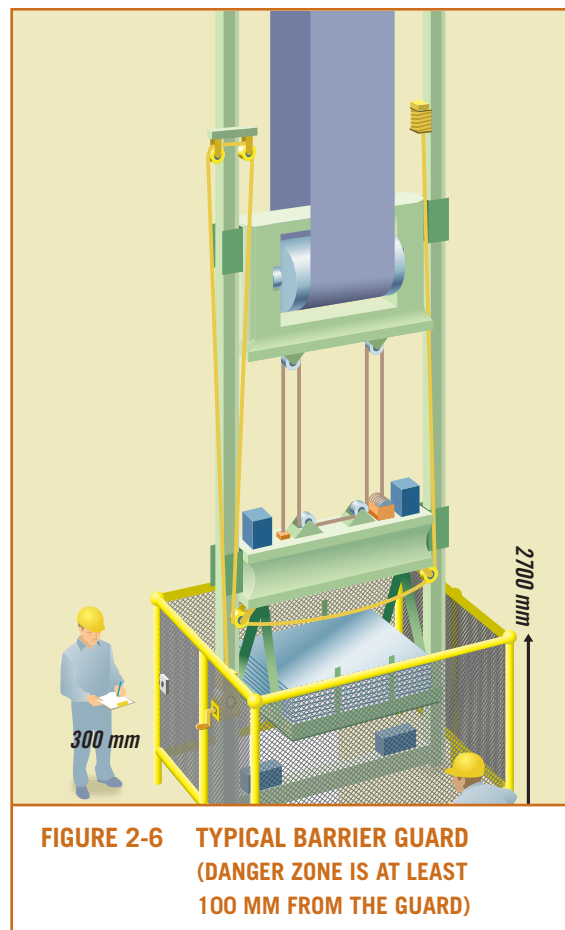


### 2.2.2.2 Barrier guards

Barrier guards do not completely surround danger zones but rather restrict or prevent access by their size and separation from the danger zone. An example is a surrounding enclosure (see Figure 2-6). For this guard to be effective it must be placed at a safe distance in accordance with the CSA Z 432-04, Safeguarding of Machinery, and there must be no wilful act to reach the danger zone (see Table 2-2). For examples illustrating use of this table, see Appendix B.

An opening of not more than 300 mm from the floor should be allowed for housekeeping.

If the vertical distance from the hazard and the bottom edge of the guard is less than 550 mm, the opening for housekeeping under the guard must be in accordance with the specifications in Table 2-1.



**TABLE 2-2 REQUIRED DISTANCES FOR FIXED BARRIER GUARDS**

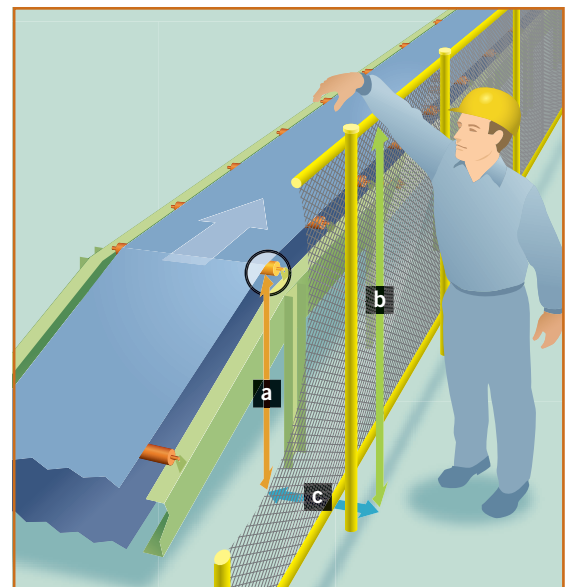
Height of danger zone (in mm)	Height of fixed barrier or protective structure* (in mm)								
	1000	1120	1400	1600	1800	2000	2200	2400	2500
2500									
2400	100	100	100	100	100	100	100	100	
2200	600	600	500	500	400	350	250		
2000	1100	900	700	600	500	350			
1800	1100	1000	900	900	600				
1600	1300	1000	900	900	500				
1400	1300	1000	900	800	100				
1200	1400	1000	900	500					
1000	1400	1000	900	300					
800	1300	900	600						
600	1200	500							
400	1200	300							
200	1100	200							
0	1100	200							

\*Protective structures less than 1000 mm in height are not included because they do not sufficiently restrict movement of the body.

### 2.2.2.3 In-running nip fixed guards

A fixed guard can be placed at a height of an in-running nip that will not allow access to this zone. In-running nip fixed guards may be form-fitting (see Figure 2-8) or made from angled deflectors with side plates (see Figure 2-9). They are well suited to an individual load conveyance, as well as to rollers and drums with a smooth, unbroken surface. They may be used in troughed conveyor belts as long as they have followed the belt profile. However, these guards are ill-suited to cleated type, ribbed or raised-edge belts.

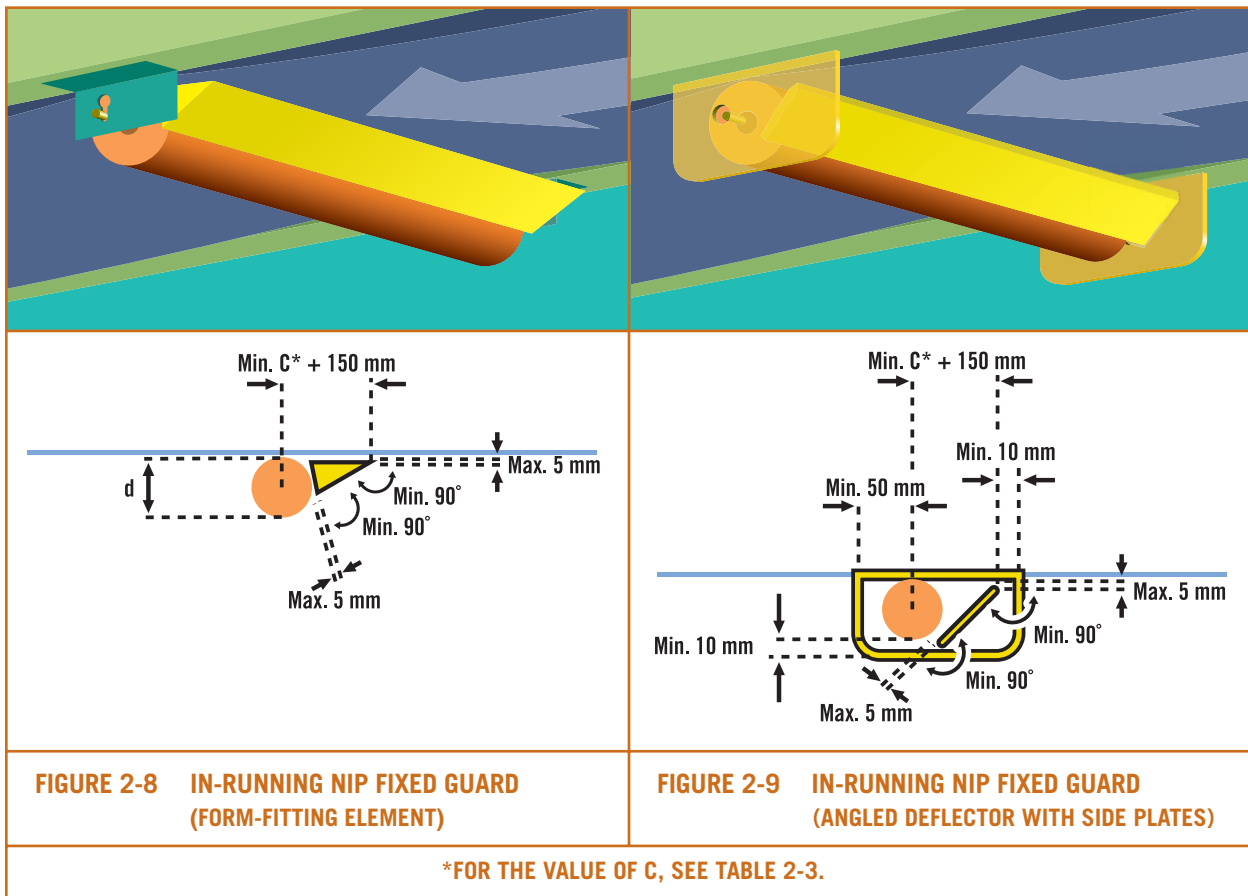
If it is impossible to maintain a maximum clearance of 5 mm between the guard and the roller or drum surface, or between the guard and the belt, then the use of the in-running nip fixed guard is not recommended.



**FIGURE 2-7 ILLUSTRATION FOR TABLE 2-2**

The minimum length that an in-running nip fixed guard must extend beyond the roller of the drum centre depends on the diameter of the roller or drum. To determine this length, first determine the maximum distance (C) which is the distance from the centre of the roller to where a finger may get pinched and be drawn in (see Table 2-3). To this distance (C), add either 150 mm for rollers or 600 mm for drums (see Figures 2-8 and 2-9).

Plates under a belt and between rollers may also serve as safeguards from in-running nips (see Figure 2-20). However, a maximum gap of 5 mm must be maintained between the roller and adjacent plates.



**TABLE 2-3 MINIMUM LENGTHS OF IN-RUNNING NIP FIXED GUARDS**

Drum or Roller Diameter d (mm)	Entrapment Zone Length C*	Minimum Guard Length from Roller Centre (C+150 mm)	Minimum Guard Length from Drum Centre (C+600 mm)
200	60	210	660
315	77	227	677
400	87	237	687
500	98	248	698
630	110	260	710
800	125	275	725
1000	140	290	740
1250	157	307	757
1400	166	316	766
1600	177	327	777

\* For roller or drum diameters not listed above.

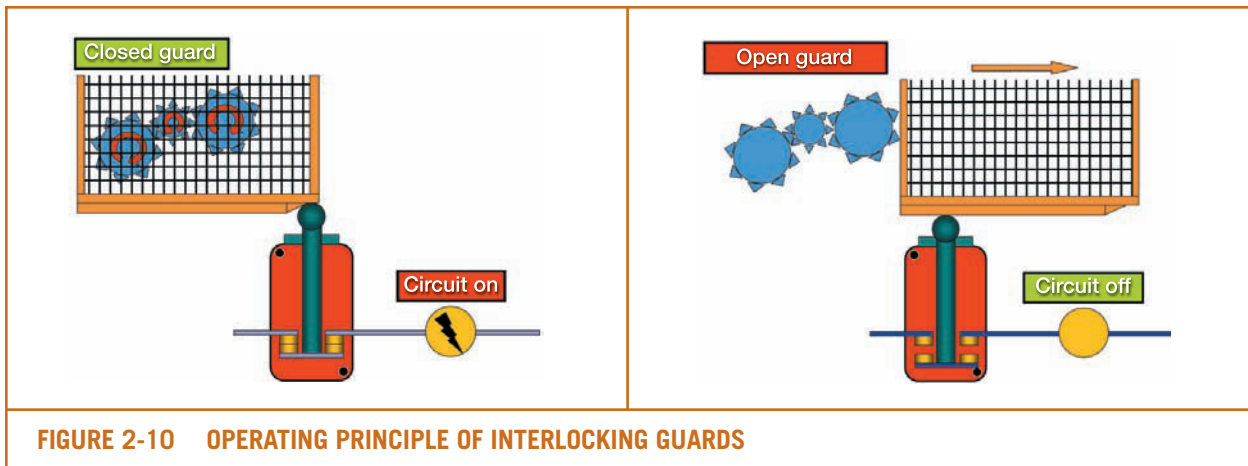
**Note:** C may be calculated using the formula:  $C = \sqrt{(d/2)^2 - [(d/2) - 20]^2}$

### 2.2.3 Interlocking guards (see Figure 2-10)

A guard equipped with an interlocking device should have the following characteristics. It should:

- ▶ cause the machine or the operation of its hazardous components to stop as it is slightly opened
- ▶ make it impossible to start the machine or to operate its hazardous components for as long as it is not in place
- ▶ not cause the machine or its hazardous components to restart once it is fully restored to its place

This type of guard may only be used if the hazard disappears before a worker can access the danger zone (low inertia conveyor with rapid stop) (see Figure 2-10).



**FIGURE 2-10 OPERATING PRINCIPLE OF INTERLOCKING GUARDS**

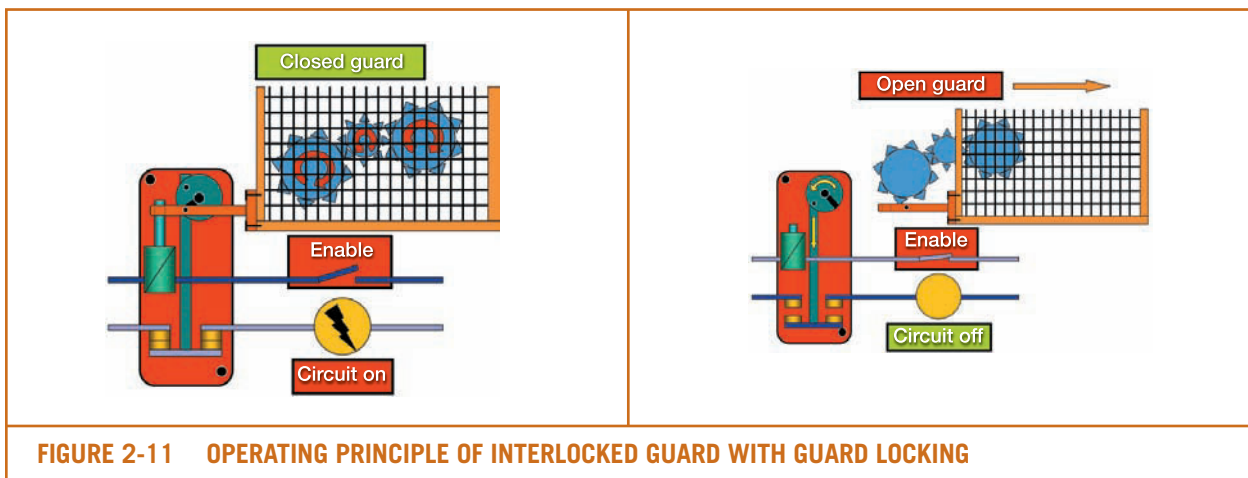
**Note:** Refer to Section 9.3 and Tables A3 through A6 of CSA Standard Z 432-04, Safeguarding of Machinery, for information about interlocking of safeguarding devices.

### 2.2.4 Interlocked guard with guard locking (see Figure 2-11)

An interlocked guard equipped with a locking device should have the following characteristics. It should:

- ▶ remain locked in place for as long as the machine or its hazardous components are moving
- ▶ make it impossible to start the machine or to operate its hazardous components for as long as it is not in place and reactivated
- ▶ not cause the machine or its hazardous components to be restarted once it is restored to its place and reactivated

This type of guard may be used when it is possible to access the danger zone before the hazard has disappeared (large inertia conveyors and long-to-stop conveyors).



**FIGURE 2-11 OPERATING PRINCIPLE OF INTERLOCKED GUARD WITH GUARD LOCKING**

## 2.3 Deterrent Devices

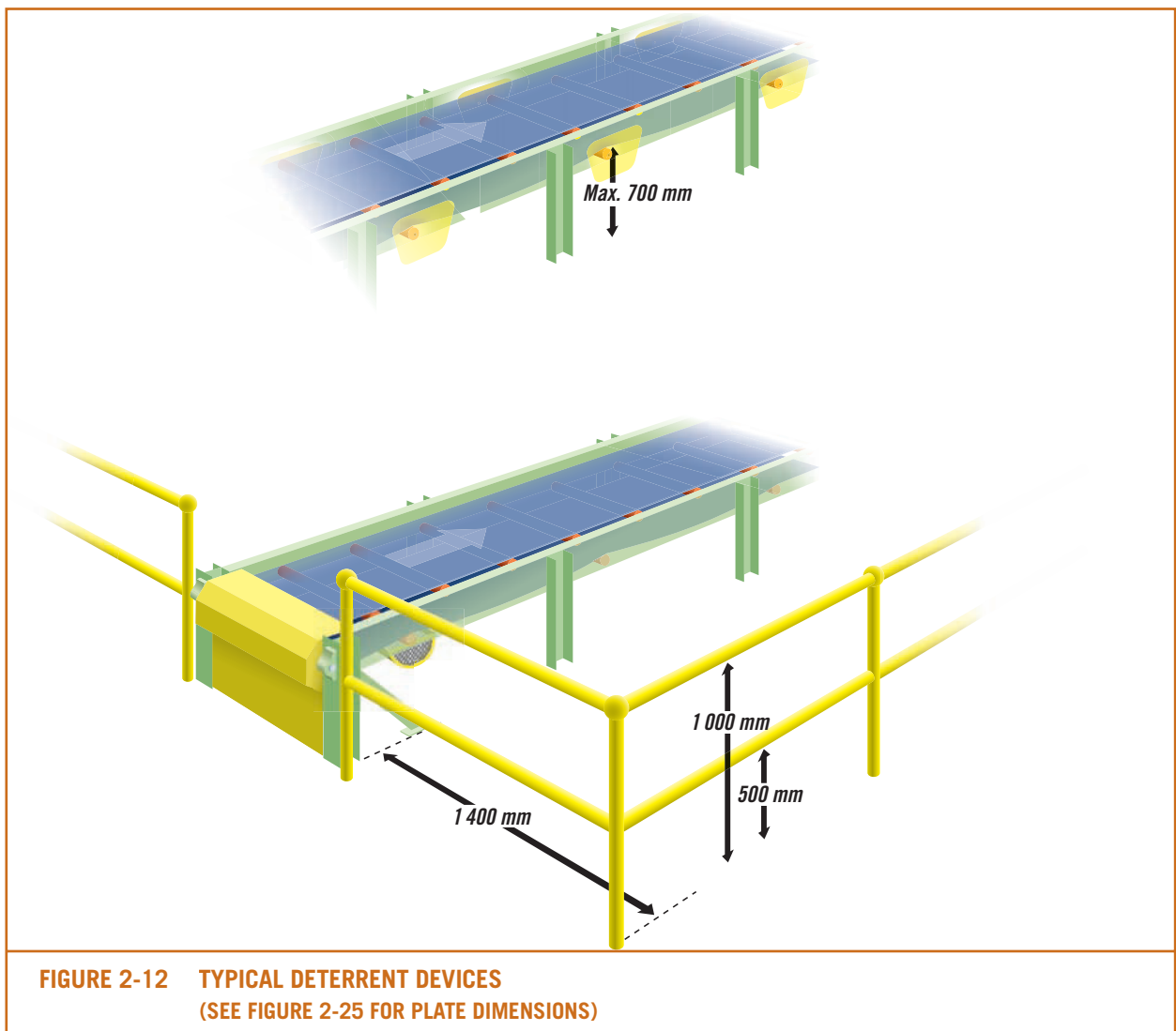
These are devices (other than guards) that reduce the risk of contact with a danger zone. They are often physical obstacles which, without totally preventing access to a danger zone, reduce the possibility of access.

Deterrent devices (see Figure 2-12) include:

- ▶ roller side plates
- ▶ guardrails with mid rails

**Note:** In order to be considered a deterrent device, guardrails must be at least 1000 mm high, with a minimum of 1400 mm separation from the danger zone. Section 315 of the OH&S Code describes the characteristics of guardrails.

Deterrent devices must be designed with operating conditions in mind. They must be capable of resisting the loads to which they will be subjected. These devices must not create additional hazards or tempt workers to bypass their use. For information on user-related characteristics (color, ease of manipulation, etc.) and construction, see Appendix A.





## 2.4 Service ways and throughways

Where service ways and throughways run parallel to or underneath conveyors, danger zones must be inaccessible and the hazards of falling conveyor parts or falling loads must be prevented. Safety requirements are outlined in section 2.6.

These measures can only be applied correctly if the throughways are well and clearly marked (painted floor lines, guardrails, etc.) Where a throughway crosses under or is located below a conveyor, the head room below the conveyor should be greater than 2 metres and the width of the throughway should be at least 600 mm. For a throughway passing over a conveyor, the foot walk must be a minimum of 1 meter wide and must be equipped with an adequate guardrail (refer to Section 373 of the OH&S Code).

Service ways can be divided into two groups:

- ▶ well-marked—for example, a foot walk along the conveyor or a single file access way under the conveyor: the measures in section 2.6 apply only to hazardous components along service ways
- ▶ poorly marked or not marked—for example, under a conveyor to permit access to certain machine elements: the measures in section 2.6 apply to all components deemed to be hazardous

## 2.5 Falling or projecting objects

Hazards of falling or projecting machine components or loads are created when machine parts break or when there is a sudden jarring in sub-assemblies.

### 2.5.1 Conveyor elements

Hazards of falling or projecting conveyor elements can be caused by the following:

- ▶ forces during normal operating conditions (centrifugal force, pressure)
- ▶ exceptional forces normally foreseeable (jarring, ramming)
- ▶ aging materials

It's important to implement measures to prevent hazards such as falling return rollers or belt breakage (see section 2.6).

### 2.5.2 Carried loads

The complete conveyor circuit, specifically loading, unloading and transfer points, must be designed to reduce the spillover hazards of carried loads.

Equipment installed high above the floor or ground must be equipped with protective devices (for example, roller restraining devices, protective plates, gutters, fillets, mesh) to prevent the fall of loads and debris. This is particularly important where conveyors are above or near throughways (see section 2.6).

## 2.6 Conveyor belt operating conditions – safety requirements

### 2.6.1 POWER TRANSMISSION MOVING PARTS

#### HAZARDS

Drive shaft; shaft end; sprocket; pulley; chain; drive belt; gear coupling

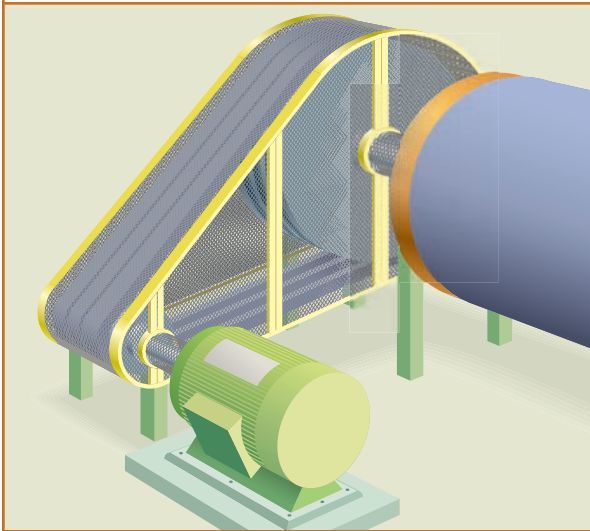
#### POTENTIAL CONSEQUENCES

Drawing-in and crushing  
Entanglement of loose clothing in protruding or moving parts

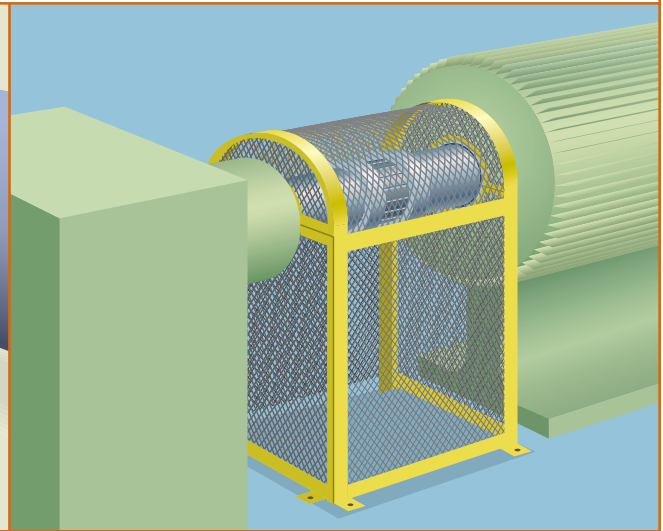
#### PROTECTIVE MEASURES

(IF A HAZARD IS LESS THAN 2700 MM FROM FLOOR OR WORKING PLATFORM)

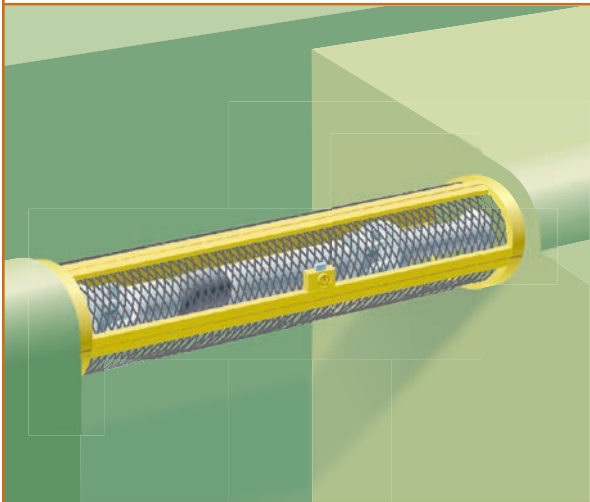
Guard all rotating devices including the rotating shaft (refer to Section 310 of the OH&S Code).



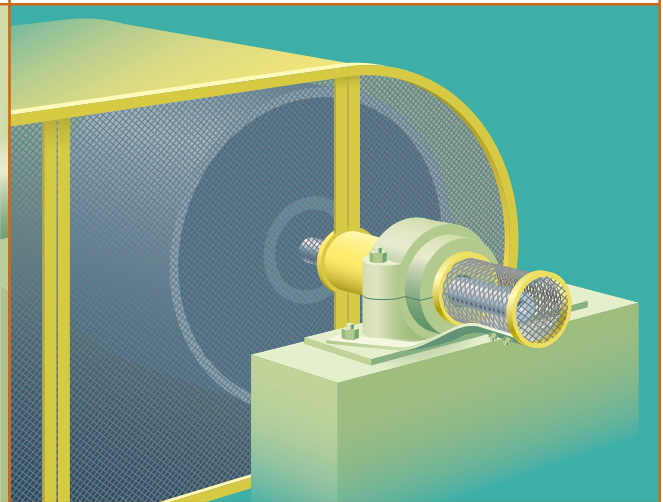
**FIGURE 2-13** SURROUNDING FIXED GUARD FOR PULLEYS AND POWER TRANSMISSION BELTS



**FIGURE 2-14** SURROUNDING FIXED GUARD FOR COUPLINGS



**FIGURE 2-15** SURROUNDING FIXED GUARD FOR SHAFTS



**FIGURE 2-16** SURROUNDING FIXED GUARD FOR SHAFT ENDS

**Note:** Extend lubrication points and belt tension adjusters outside the guards.

## 2.6.2 BELTS

### HAZARD

Belt in good condition

### POTENTIAL CONSEQUENCES (DEPENDING UPON BELT CHARACTERISTICS AND SPEED)

Friction burns or abrasion  
Impact with belt, drawing-in

### PROTECTIVE MEASURES

(IF HAZARD IS LESS THAN 2700 MM FROM FLOOR OR WORKING PLATFORM)

#### LOAD STRAND:

##### Workstation:

Install guard, as per hazard assessment.

#### RETURN STRAND:

##### Workstation

Install guard, as per hazard assessment.

##### Throughway parallel to conveyor

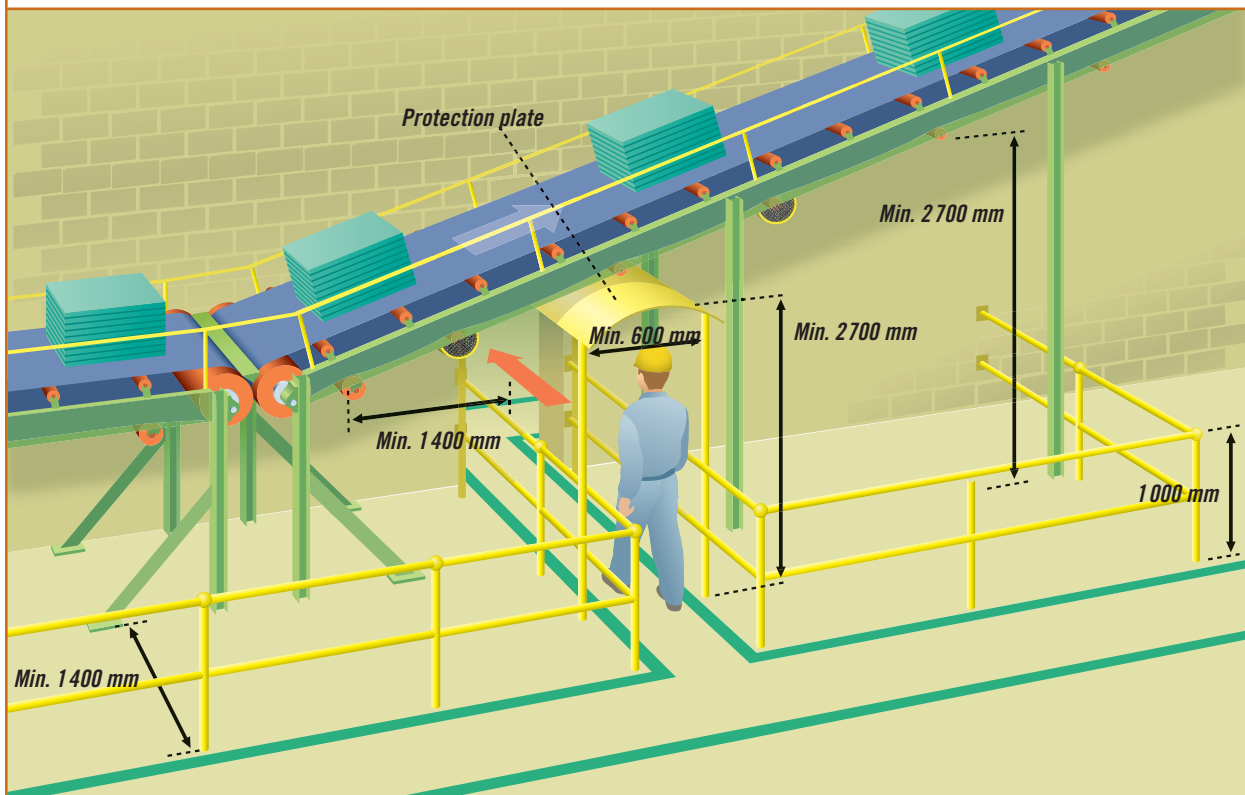
Install guardrail, as per hazard assessment.

##### Throughway passing under conveyor

Install protection plate (able to withstand belt impact in case of breakage),  
as per hazard assessment.

##### Service way passing under conveyor

Install protection plate, as per hazard assessment.



**FIGURE 2-17** TYPICAL PROTECTIVE MEASURES FOR THROUGHWAYS

**Note:** Cleated, ribbed or raised-edge belts present additional hazards (impact, drawing-in) which must be considered during the hazard assessment.

## 2.6.2 BELTS (continued)

### HAZARDS

Deteriorated belt or belt splice

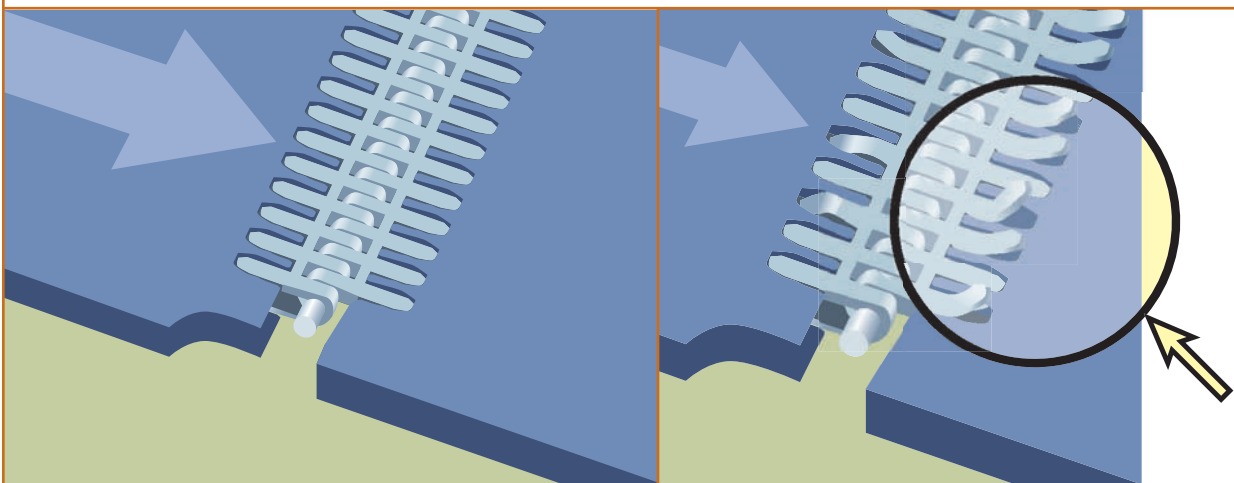
### POTENTIAL CONSEQUENCES

Drawing-in, burns, pokes, cuts

### PROTECTION MEASURES

(IF HAZARD IS LESS THAN 2700 MM FROM FLOOR OR WORKING PLATFORM)

Change the belt splice design or manufacture.  
Maintain belt and/or splice.



A - Splice in proper condition

B - Damaged splice

### FIGURE 2-18 MECHANICAL SPLICES

**Note:** Mechanical splices may require extra cleanup that may result in greater exposure to workers doing the cleanup.

## 2.6.3 CONVEYOR BELTS IN A STRAIGHT RUN

### HAZARDS

In-running nips between the rollers/load beds under the hopper  
Load side under the skirtboard or skirt

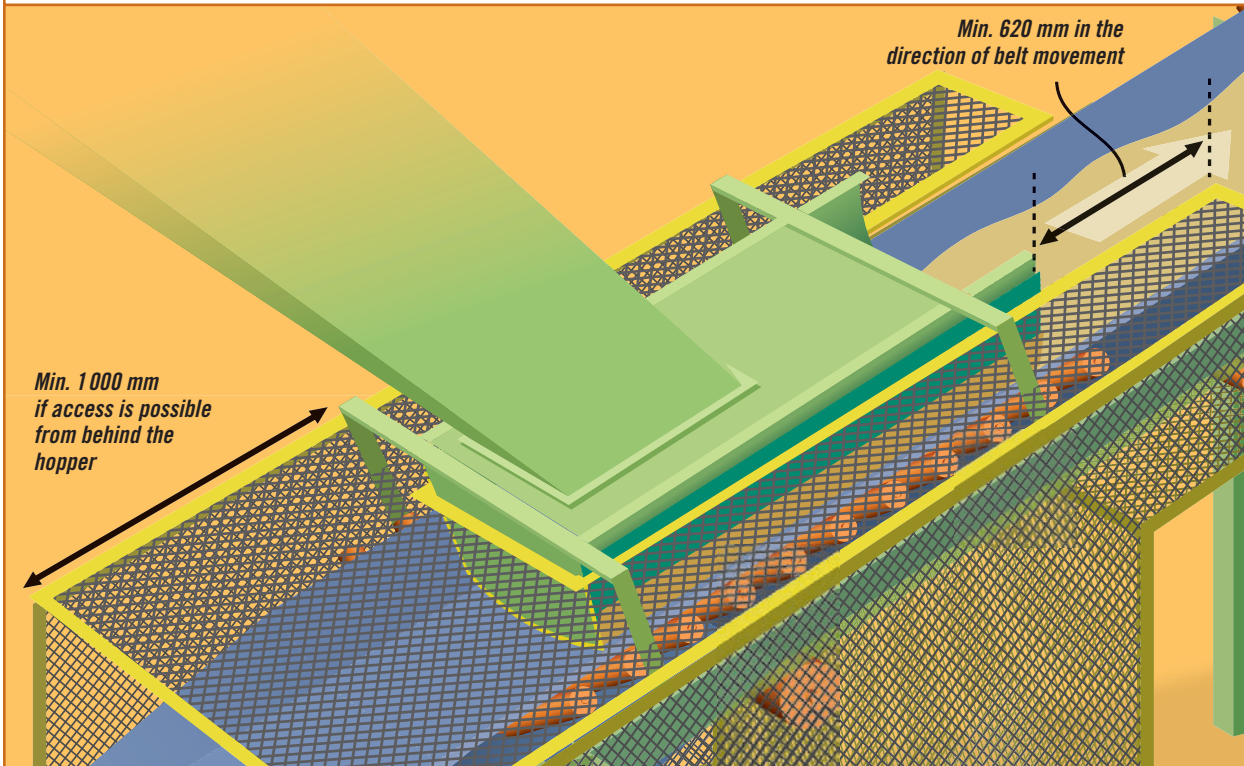
### POTENTIAL CONSEQUENCES

Drawing-in, Shearing  
Belt burns

### PROTECTIVE MEASURES

(IF HAZARD IS LESS THAN 2700 MM FROM FLOOR OR WORKING PLATFORM)

Install surrounding or barrier guard.



**FIGURE 2-19** SURROUNDING FIXED GUARD IN LOADING AREA

**Note:** Extend lubrication points beyond the guards.

## 2.6.3 CONVEYOR BELTS IN A STRAIGHT RUN (continued)

### HAZARDS

In-running nips between load side and support rollers in a straight run

### POTENTIAL CONSEQUENCES

Drawing-in

### PROTECTIVE MEASURES

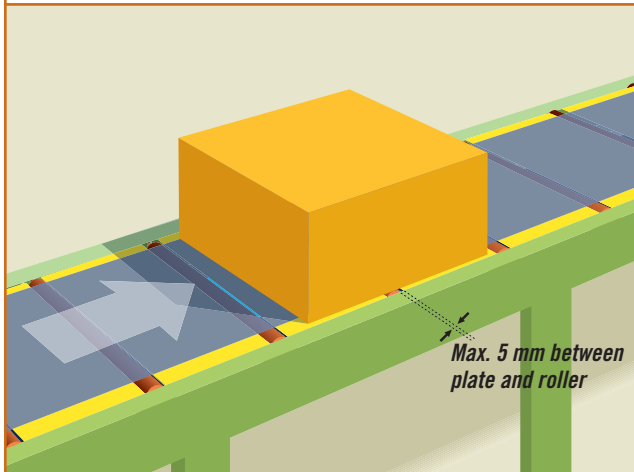
(IF HAZARD IS LESS THAN 2700 MM FROM FLOOR OR WORKING PLATFORM)

#### Workstation:

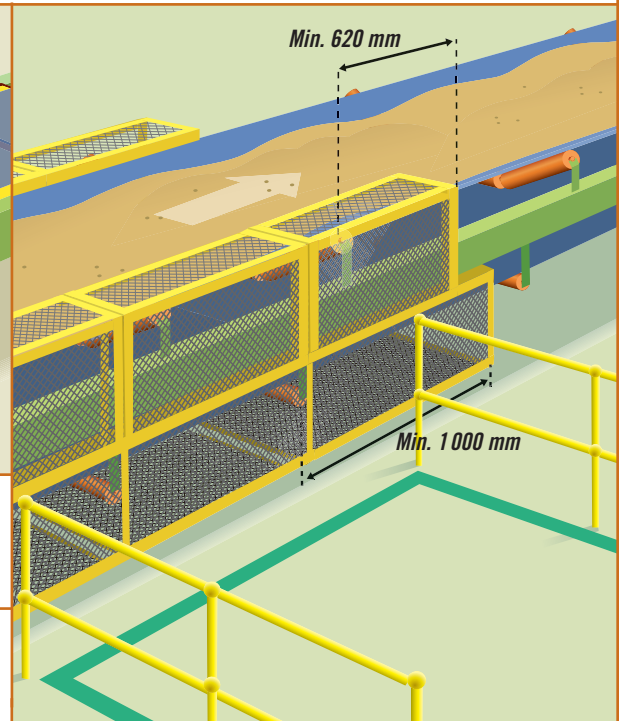
Install surrounding fixed guard (plates between rollers).

#### Throughway and service way:

As determined by hazard assessment.



**FIGURE 2-20** IN-RUNNING NIP FIXED GUARD FOR SUPPORT ROLLERS (PLATES)



**FIGURE 2-21** SURROUNDING FIXED GUARD FOR SUPPORT ROLLERS

**Note:** Special Case—When support rollers are themselves supported from above, this configuration must be taken into account during the hazard assessment.

## 2.6.3 CONVEYOR BELTS IN A STRAIGHT RUN (continued)

### HAZARDS

In-running nips between lower strand and return rollers in a straight run (1 of 3)

### POTENTIAL CONSEQUENCES

Dragging  
Impact with rollers (may lead to severe injury or fatality)

### PROTECTIVE MEASURES

(IF HAZARD IS LESS THAN 2700 MM FROM FLOOR OR WORKING PLATFORM)

#### Workstation (beside or under conveyor)

Install surrounding or in-running nip guards and additional protection plates if the control station is located below return rollers.

#### Throughway parallel to conveyor

(IF IN-RUNNING NIP IS LOCATED AT A HEIGHT LESS THAN 700 MM)

Install deterrent devices (guardrail side plate).

(IF IN-RUNNING NIP IS LOCATED AT A HEIGHT BETWEEN 700 MM AND 2700 MM)

Install surrounding in-running nip guard or barrier guard, or other deterrent devices (guardrail).\*

#### Throughway under a conveyor

Install surrounding in-running nip or barrier guards or deterrent devices (guardrail)\* and add protection plates.

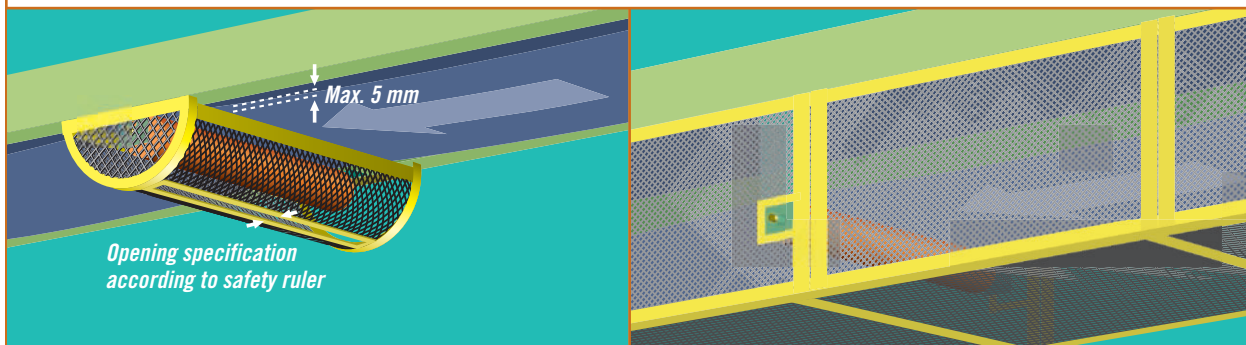


FIGURE 2-22 SURROUNDING FIXED GUARD FOR RETURN ROLLERS

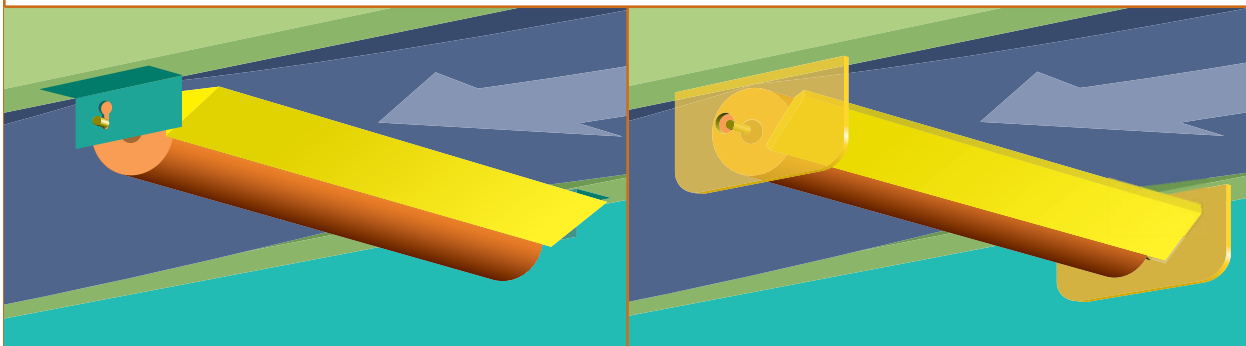


FIGURE 2-23 IN-RUNNING NIP FIXED GUARDS FOR RETURN ROLLERS

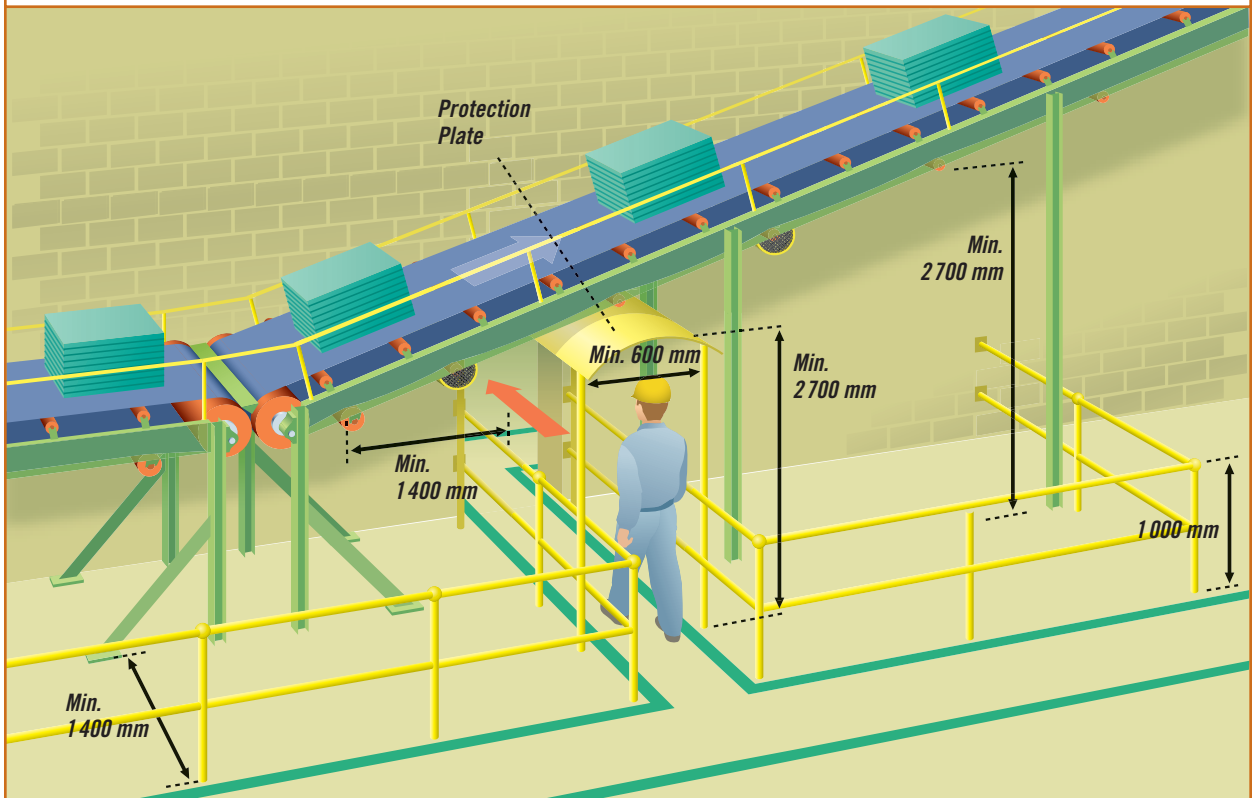
**Note:** See Figures 2-8 and 2-9 and Table 2-3 for dimensions.

\*If, after the hazard assessment, another solution is deemed appropriate, it may be adopted

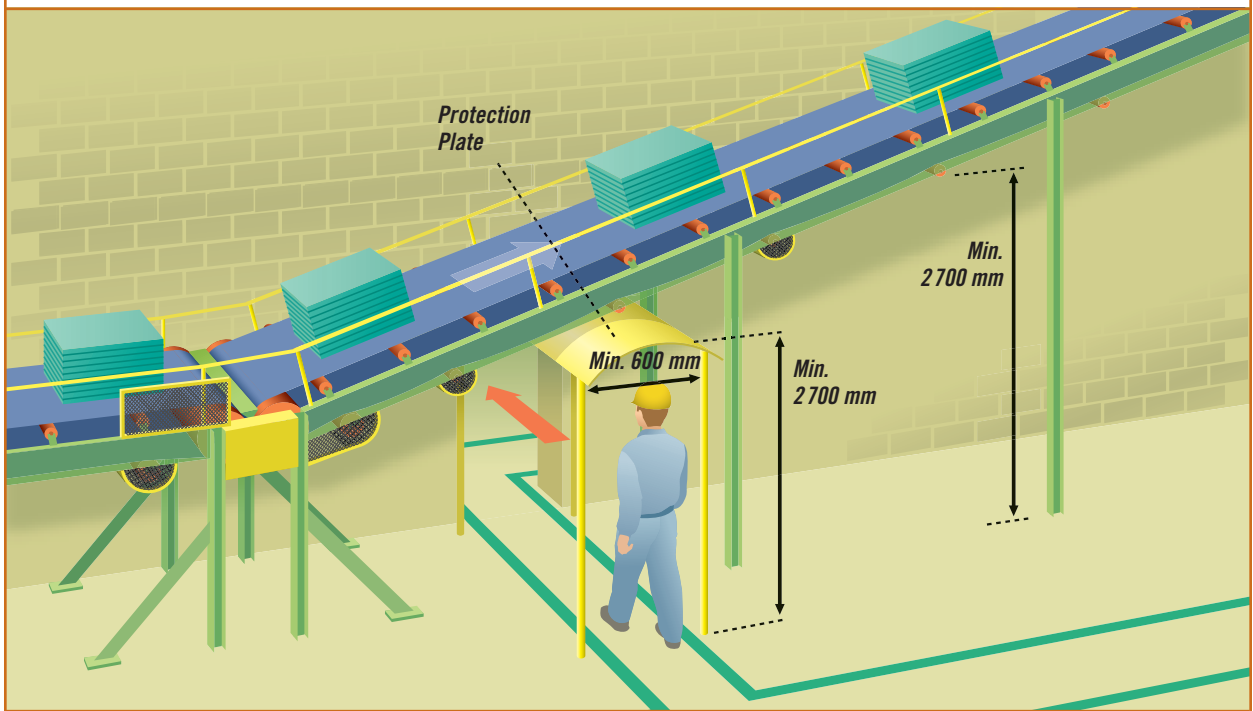
## 2.6.3 CONVEYOR BELTS IN A STRAIGHT RUN (continued)

### HAZARDS

In-running nips between lower strand and return rollers in a straight run (2 of 3)



A - Protection Plate and Deterrent Device (Guardrail)



B - Protection Plate and Surrounding Fixed Guards

FIGURE 2-24 TYPICAL PROTECTIVE DEVICES FOR THROUGHWAYS

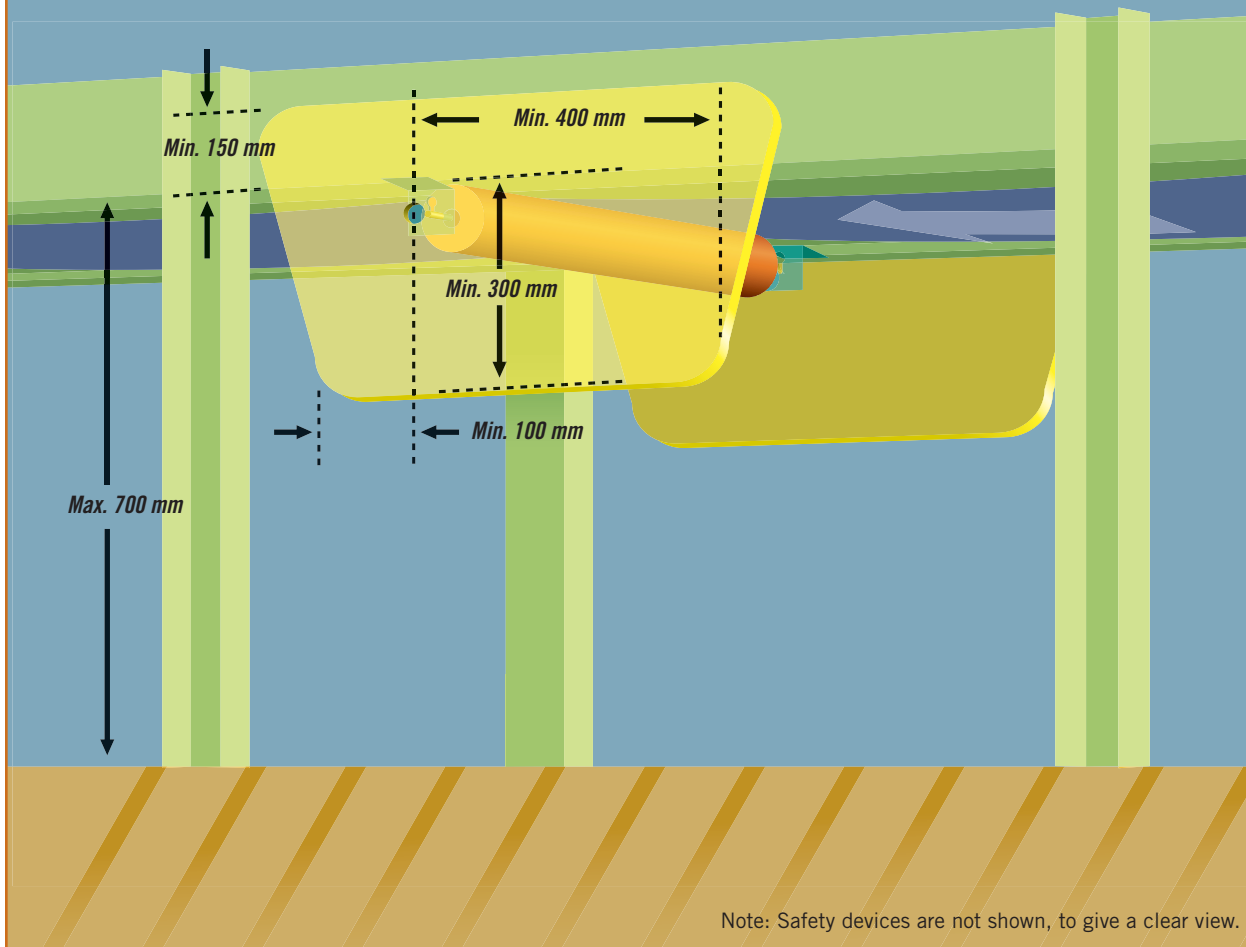


### 2.6.3 CONVEYOR BELTS IN A STRAIGHT RUN (continued)

#### HAZARD

In-running nips between lower strand and return rollers in a straight run only **(3 of 3)**

This deterrent device can be used only with a belt no higher than 700 mm from the floor and when housekeeping is done while the conveyor is not operating.



**FIGURE 2-25 DETERRENT DEVICE (SIDE PLATE) FOR RETURN ROLLERS LOCATED LESS THAN 700 MM FROM THE FLOOR (NOTE RESTRICTIONS ON USE)**

## 2.6.3 CONVEYOR BELTS IN A STRAIGHT RUN (continued)

### HAZARD

Return rollers

### POTENTIAL CONSEQUENCES

Impact with rollers  
Crushing by falling rollers

### PROTECTIVE MEASURES

**(IF THROUGHWAY IS MORE THAN 2700 MM BELOW CONVEYOR):**

Install retaining device for return rollers, as per hazard assessment.  
It is possible to reduce risk with a preventive maintenance program,  
which should be taken into account when doing the hazard assessment.

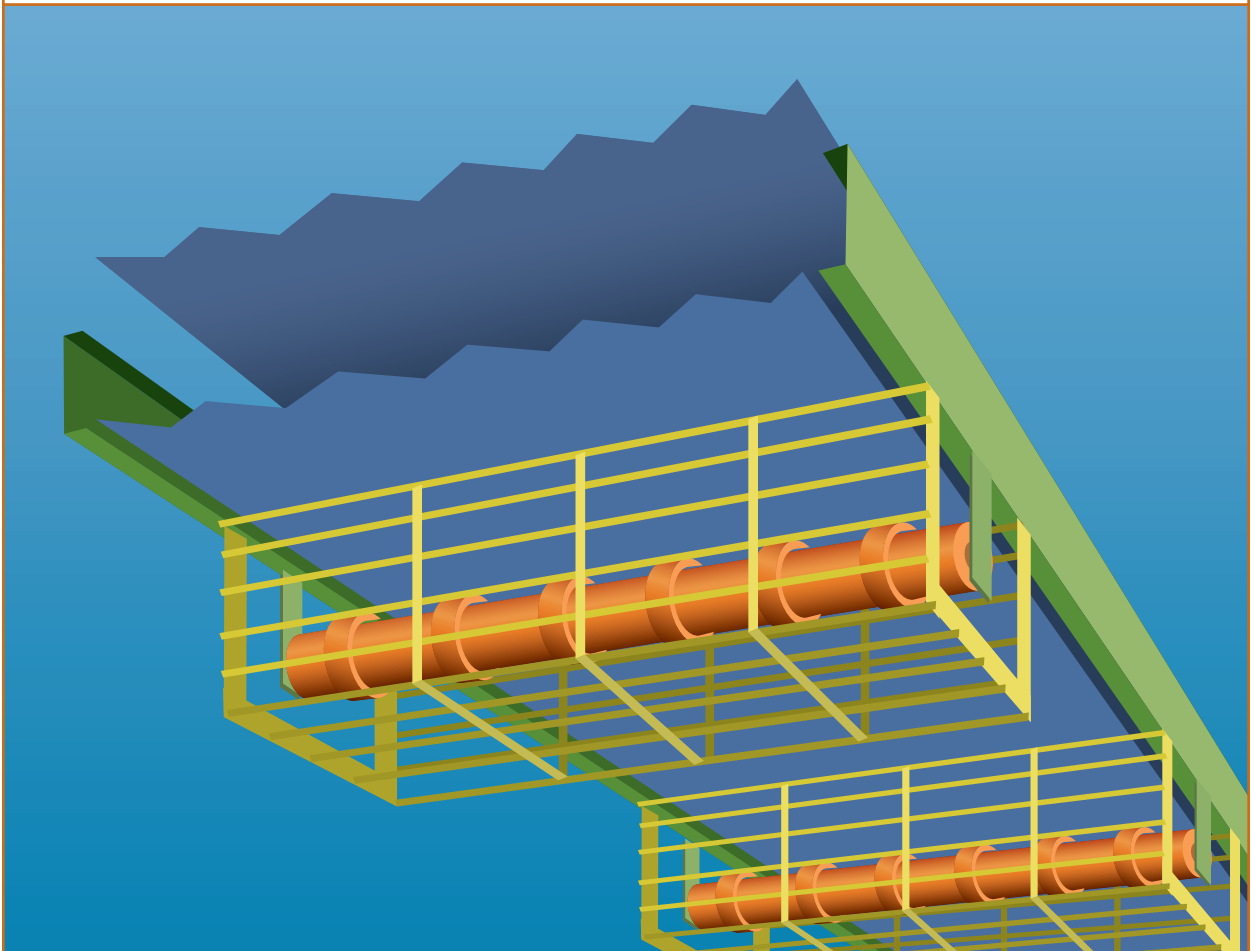


FIGURE 2-26 RETURN ROLLER RETAINING DEVICE

### 2.6.3 CONVEYOR BELTS IN A STRAIGHT RUN (continued)

#### HAZARD

Return strand scrapers

#### POTENTIAL CONSEQUENCES

Trapping and crushing  
Belt abrasions  
Severe injury fatality

#### PROTECTIVE MEASURES

(IF HAZARD IS LESS THAN 2700 MM FROM FLOOR OR WORKING PLATFORM)

In accordance with hazard assessment results, the scraper protection device may be combined with a drum protection device.

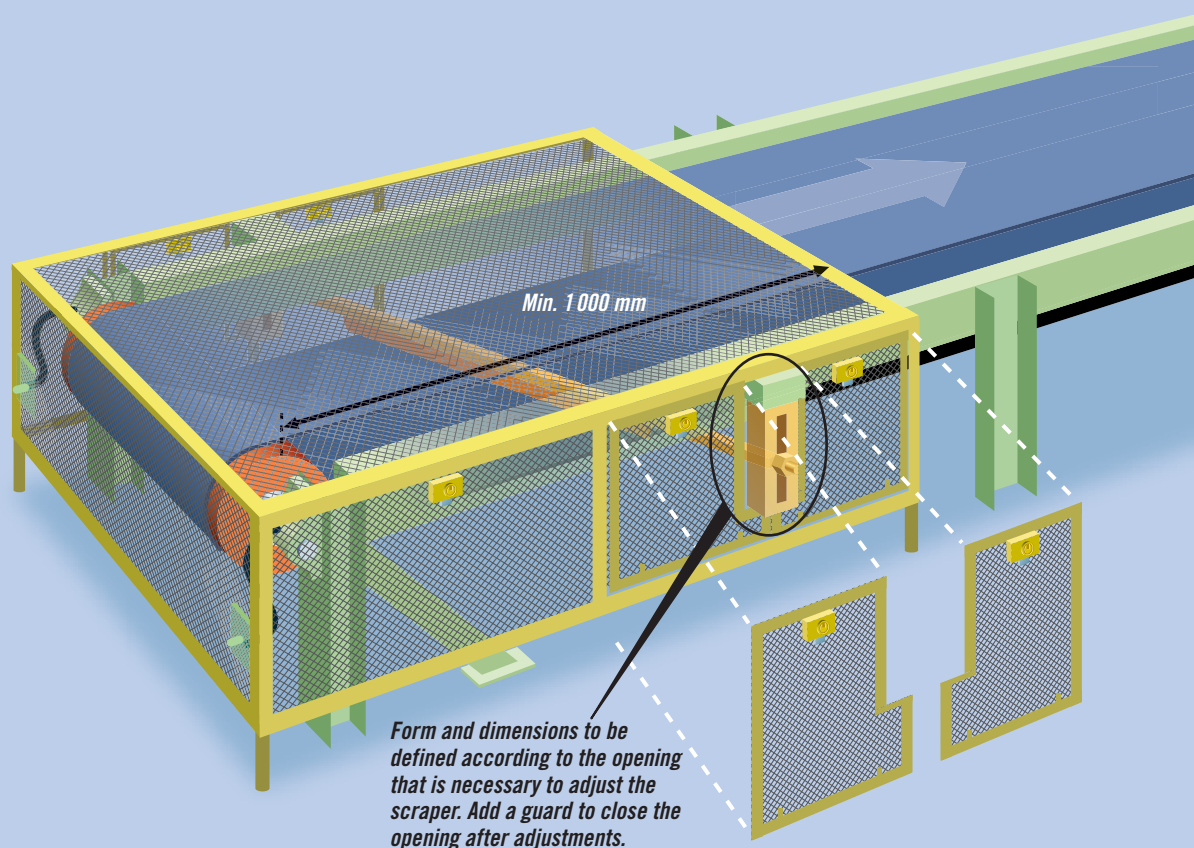


FIGURE 2-27 SURROUNDING BARRIER GUARD FOR DRUM AND SCRAPER (PARTIAL CAGE)

## 2.6.4 CURVED ZONE

### HAZARDS

In-running nip between the belt and rollers in the curved zone

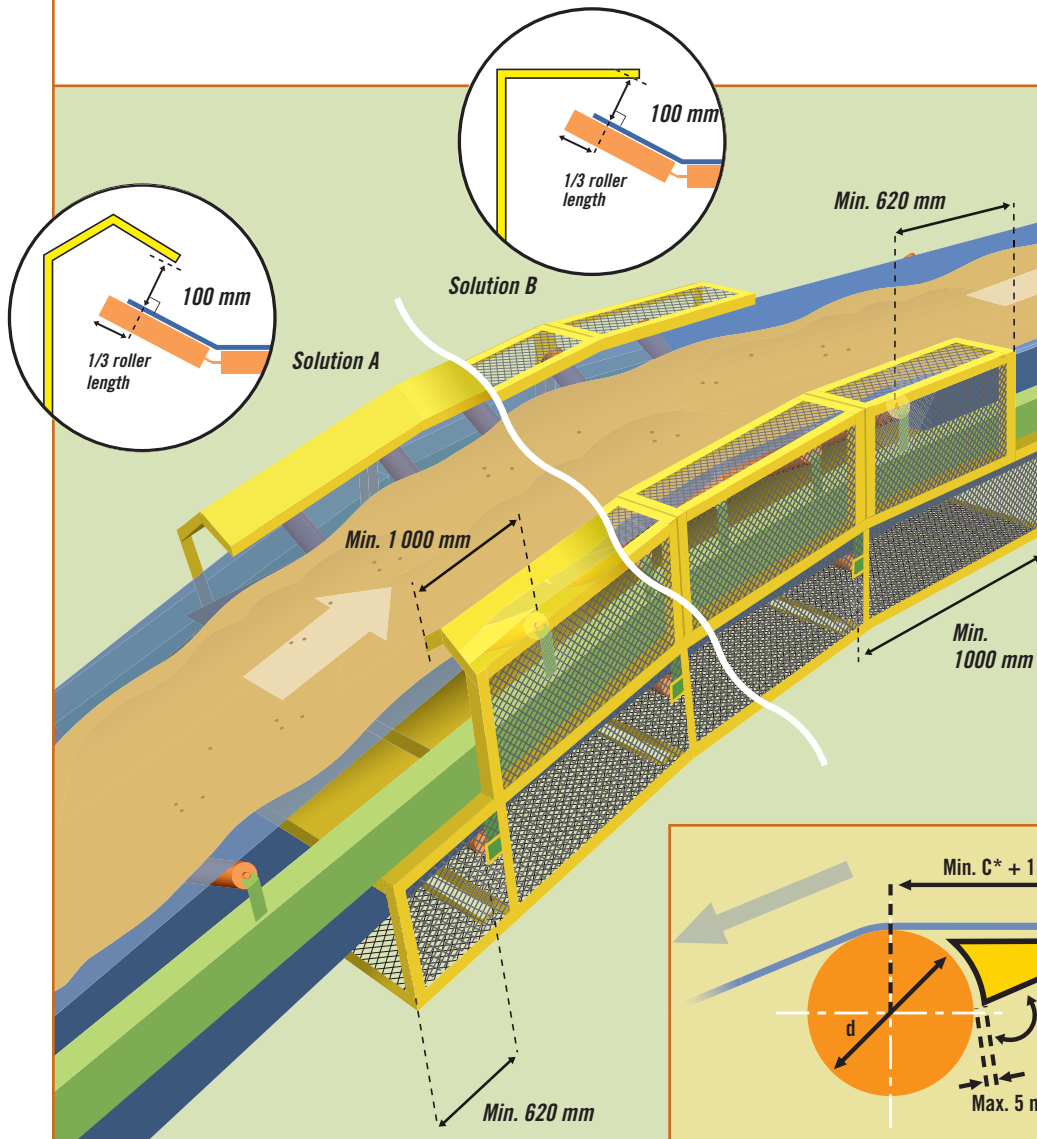
### POTENTIAL CONSEQUENCES

Drawing-in

### PROTECTIVE MEASURES

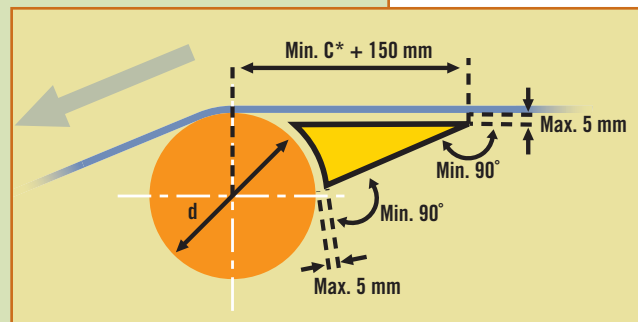
(IF HAZARD IS LESS THAN 2700 MM FROM FLOOR OR WORKING PLATFORM)

Install surrounding in-running nip or separation barrier guard.



**FIGURE 2-28** SURROUNDING FIXED GUARDS FOR CURVED ZONE

**Note:** Belt edge tension is greater in the curved zones.



**FIGURE 2-29** CURVED ZONE IN-RUNNING NIP GUARD  
\*SEE TABLE 2-3 FOR C DIMENSIONS

## 2.6.5 TRANSITION ZONE

### HAZARD

In-running nips between the load side and the load carrying rollers in the transition zone

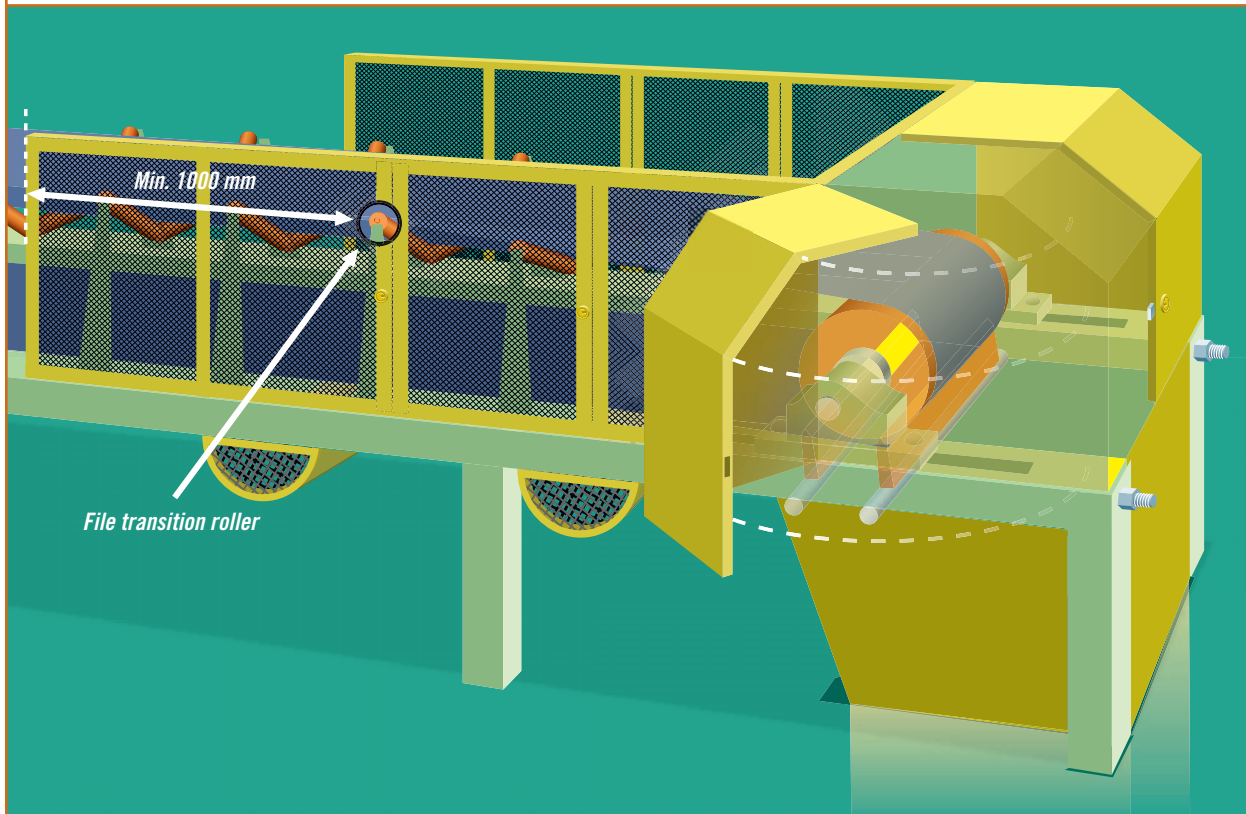
### POTENTIAL CONSEQUENCES

Drawing-in

### PROTECTIVE MEASURES

(IF HAZARD IS LESS THAN 2700 MM FROM THE FLOOR OR WORKING PLATFORM)

Install surrounding or in-running nip guard.



**FIGURE 2-30** PROTECTORS FOR HEAD DRUM AND TRANSITION ZONE  
(TO DETERMINE LATERAL SCREEN HEIGHT, SEE TABLE 2-2)

## 2.6.6 DRUMS

### HAZARDS

In-running nips between belt and drums. (1 of 2)

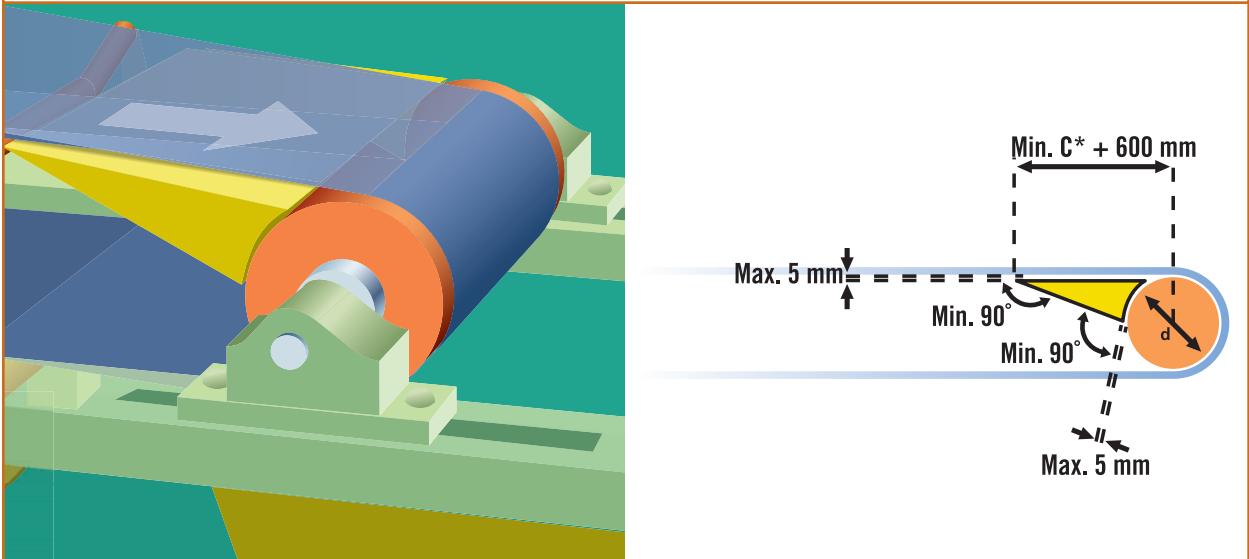
### POTENTIAL CONSEQUENCES

Drawing-in  
Severe injury/fatality

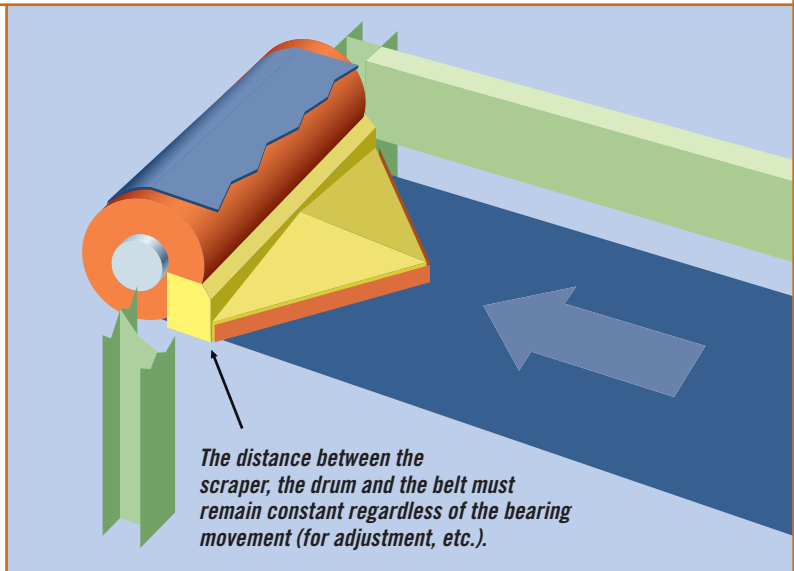
### PROTECTIVE MEASURES

(IF HAZARD IS LESS THAN 2700 MM FROM THE FLOOR OR WORKING PLATFORM)

Install surrounding in-running nip or barrier guards.



**FIGURE 2-31 IN-RUNNING NIP GUARD FOR DRUM**  
\*SEE TABLE 2-3 FOR C DIMENSIONS

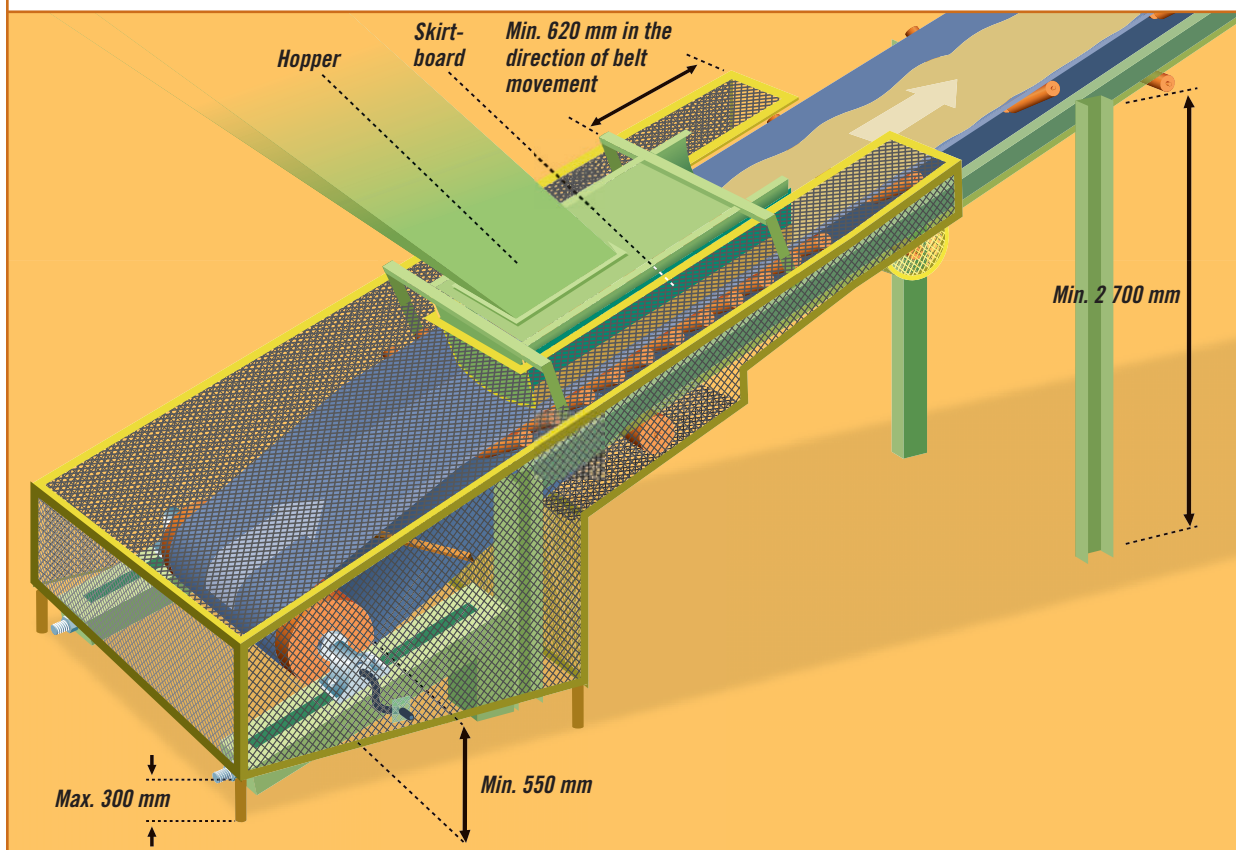


**FIGURE 2-32 SCRAPERS SERVING AS AN IN-RUNNING NIP GUARD**

## 2.6.6 DRUMS (continued)

### HAZARD

In-running nips between belt and drums. (2 of 2)



**FIGURE 2-33** SURROUNDING FIXED GUARD FOR TAIL DRUM

**Note:** If it is not possible to comply with the 550 mm minimum distance between the in-running nip and the bottom edge of the surrounding fixed guard, the opening for housekeeping should be in accordance with Table 2-1.

## 2.6.6 DRUMS (continued)

### HAZARD

Take-up system

### POTENTIAL CONSEQUENCES

Crushed by falling weights  
Drawn-in at pinch points  
Severe injury/fatality

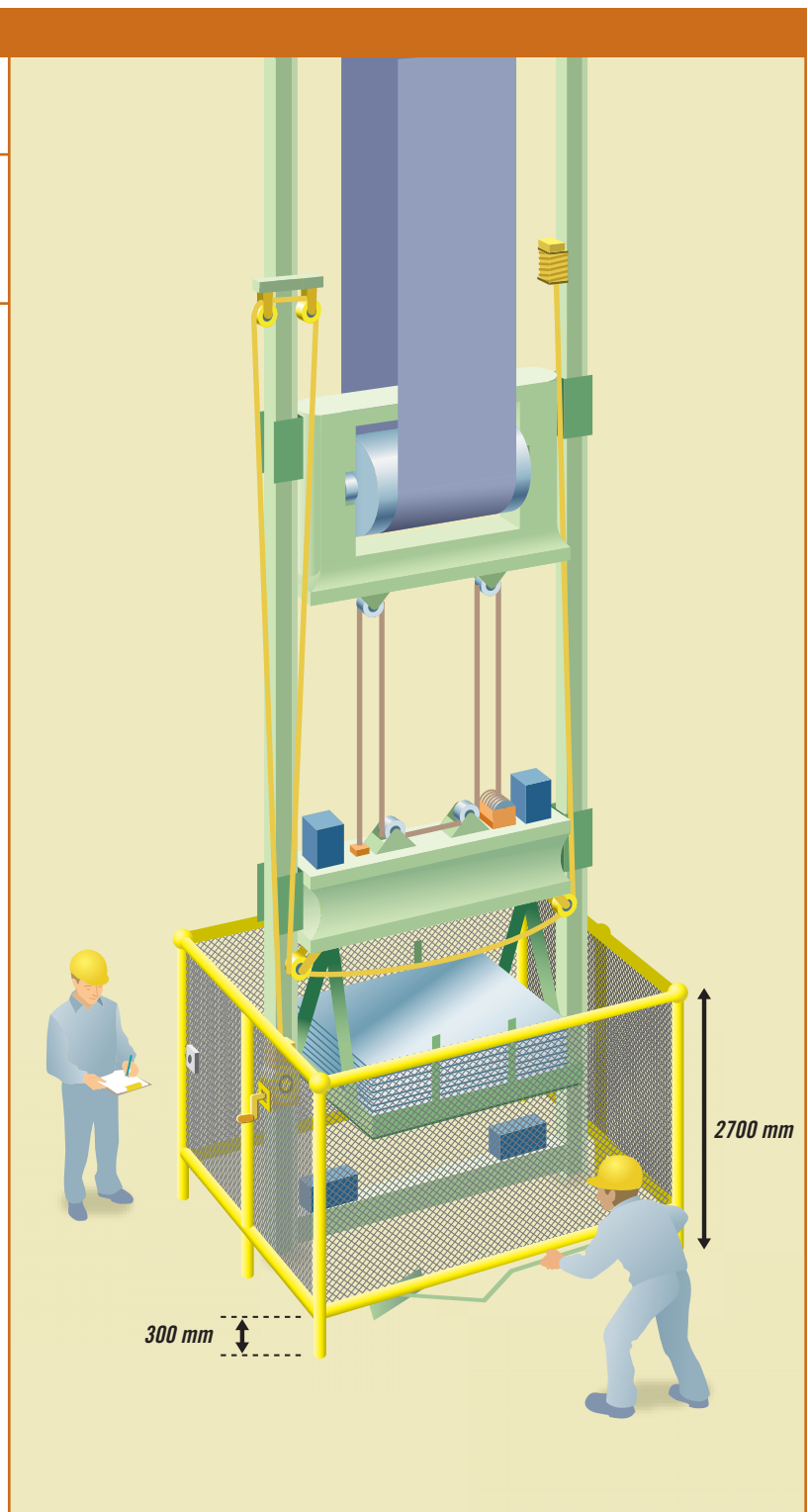
### PROTECTIVE MEASURES

(IF HAZARD IS LESS THAN 2700 MM  
FROM FLOOR OR WORKING PLATFORM)

Install surrounding  
or barrier guards.

(IF HAZARD IS LESS THAN 2700 MM  
FROM FLOOR OR WORKING PLATFORM)

Install deterrent device  
(guardrail) to prevent access  
under the weight.



**FIGURE 2-34 BARRIER GUARD FOR GRAVITY-TYPE TENSIONER**

**Note:** For gravity-type tensioning devices, the heights of the barrier preventing access under the counterweight should be 2500 mm. Tensioner drums (head or tail) should also be protected.



## 2.6.6 DRUMS (continued)

### HAZARD

(IF GAP IS GREATER THAN 5 MM)

Junction between two conveyors

### POTENTIAL CONSEQUENCES

Drawing-in and trapping

### PROTECTIVE MEASURES

(IF HAZARD IS LESS THAN 2700 MM FROM THE FLOOR OR WORKING PLATFORM)

Install fixed guard (plate) or free-wheeling pop-up roller.

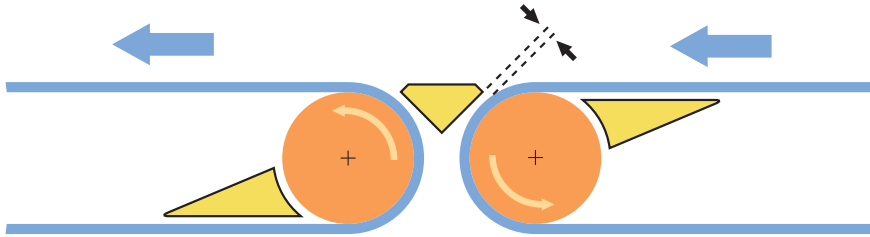


FIGURE 2-35 FIXED GUARD AT CONVEYOR BELT JUNCTION

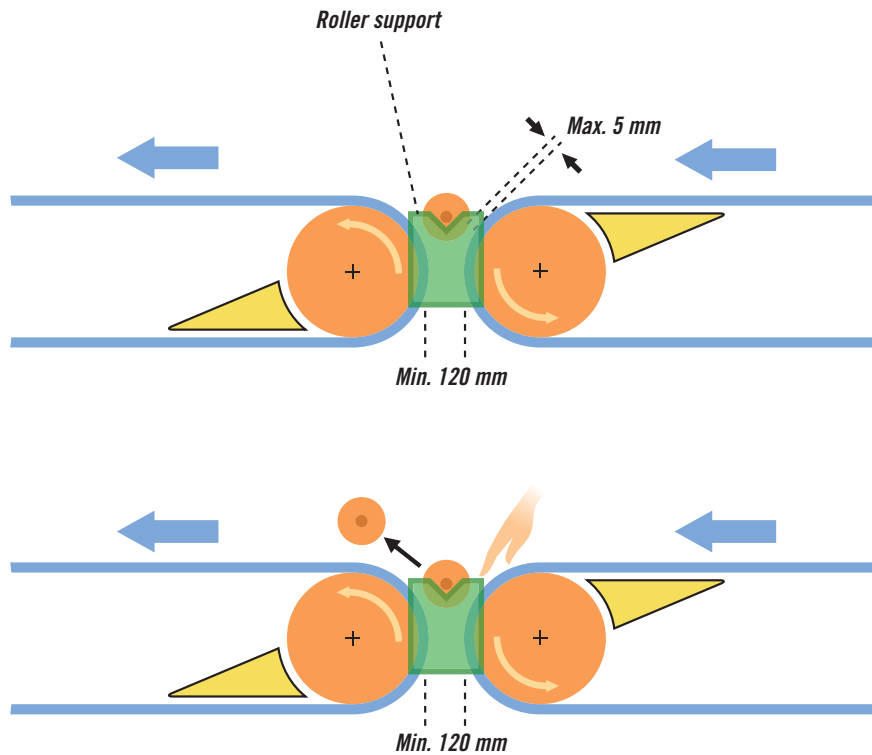


FIGURE 2-36 POP-UP ROLLERS AT CONVEYOR BELT JUNCTION

## 2.6.7 MOVING LOADS

### HAZARDS

Skirtboards  
Individual moving loads

### POTENTIAL CONSEQUENCES

Trapping between belt and skirtboard or between load and skirtboard

### PROTECTIVE MEASURES

(IF HAZARD IS LESS THAN 2700 MM FROM FLOOR OR WORKING PLATFORM)

#### Workstation

Limit gap between skirtboard and belt to a maximum of 5 mm.  
Remove skirtboard.  
Design a surrounding fixed guard, if need determined by hazard assessment.

#### Other Areas

Hazard assessment.

**Note:** When doing the hazard assessment, take into account the possibility of falling guards with the removal of the skirtboard.

## 2.6.7 MOVING LOADS (continued)

### HAZARD

Individual loads and fixed obstacles not part of the conveyor, e.g., post, wall, tunnel entrance, enclave, associated fixed equipment (such as detectors), etc.  
Large or bulky loads (such as boulders)

### POTENTIAL CONSEQUENCES

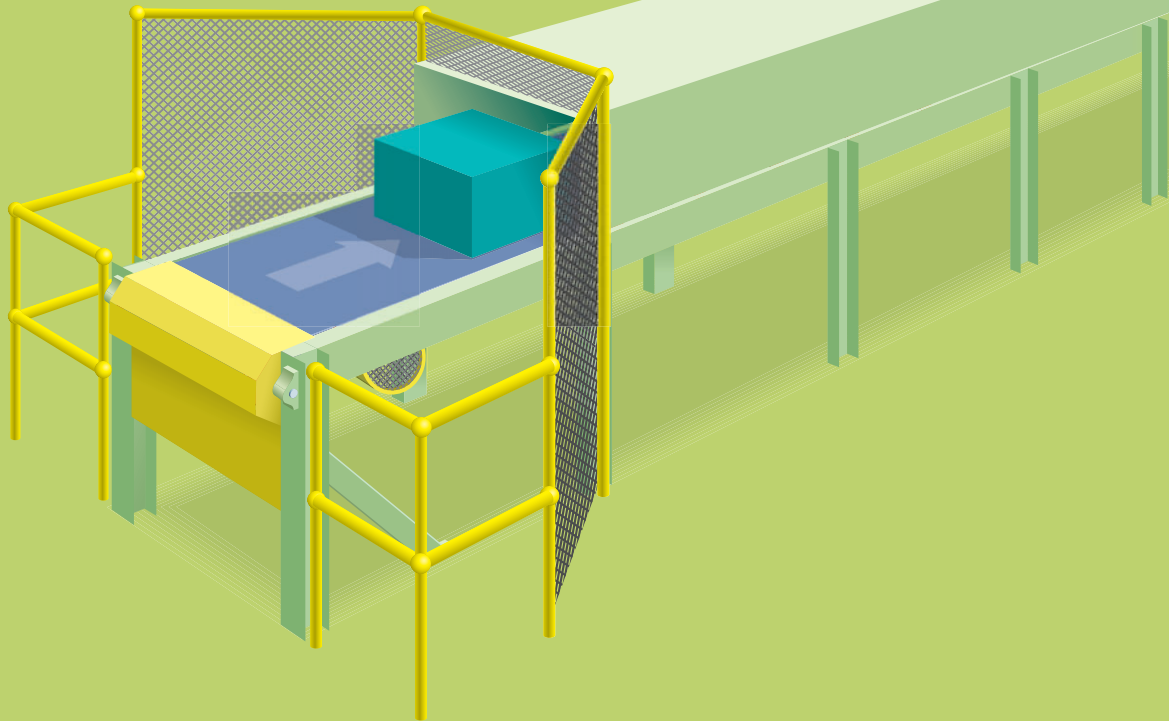
Crushing between loads and fixed objects  
Shearing  
Impact with loads or other objects

### PROTECTIVE MEASURES

(IF HAZARD IS LESS THAN 2700 MM FROM FLOOR OR WORKING PLATFORM)

Fixed guard or deterrent device in accordance with hazard assessment results, in respecting the safe distances between loads and obstacles. The following are the minimum distances for different situations:

If entire body can be drawn in: 500 mm  
If arms can be drawn in: 120 mm  
If legs can be drawn in: 180 mm



**FIGURE 2-37** TYPICAL PROTECTIVE MEASURES AGAINST HAZARDS ASSOCIATED WITH INDIVIDUAL LOADS AND FIXED OBSTACLES

**Note:** The objective is to keep the body, arms and legs away from the crushing area. The type of guard and its dimensions will depend upon the body part at risk of being trapped and the weight of the load, as determined by the hazard assessment. The guard in itself must not create a drawing-in or trapping area.

## 2.6.7 MOVING LOADS (continued)

### HAZARD

Load and load carrying rollers exceeding belt width

### POTENTIAL CONSEQUENCES

Trapping  
Crushing

### PROTECTIVE MEASURES

(IF HAZARD IS LESS THAN 2700 MM FROM FLOOR OR WORKING PLATFORM)

#### Workstation

Install fixed barrier guard (separation type or plates between rollers).

#### Other areas

Install fixed barrier guard (separation type or plates between rollers) or deterrent device.

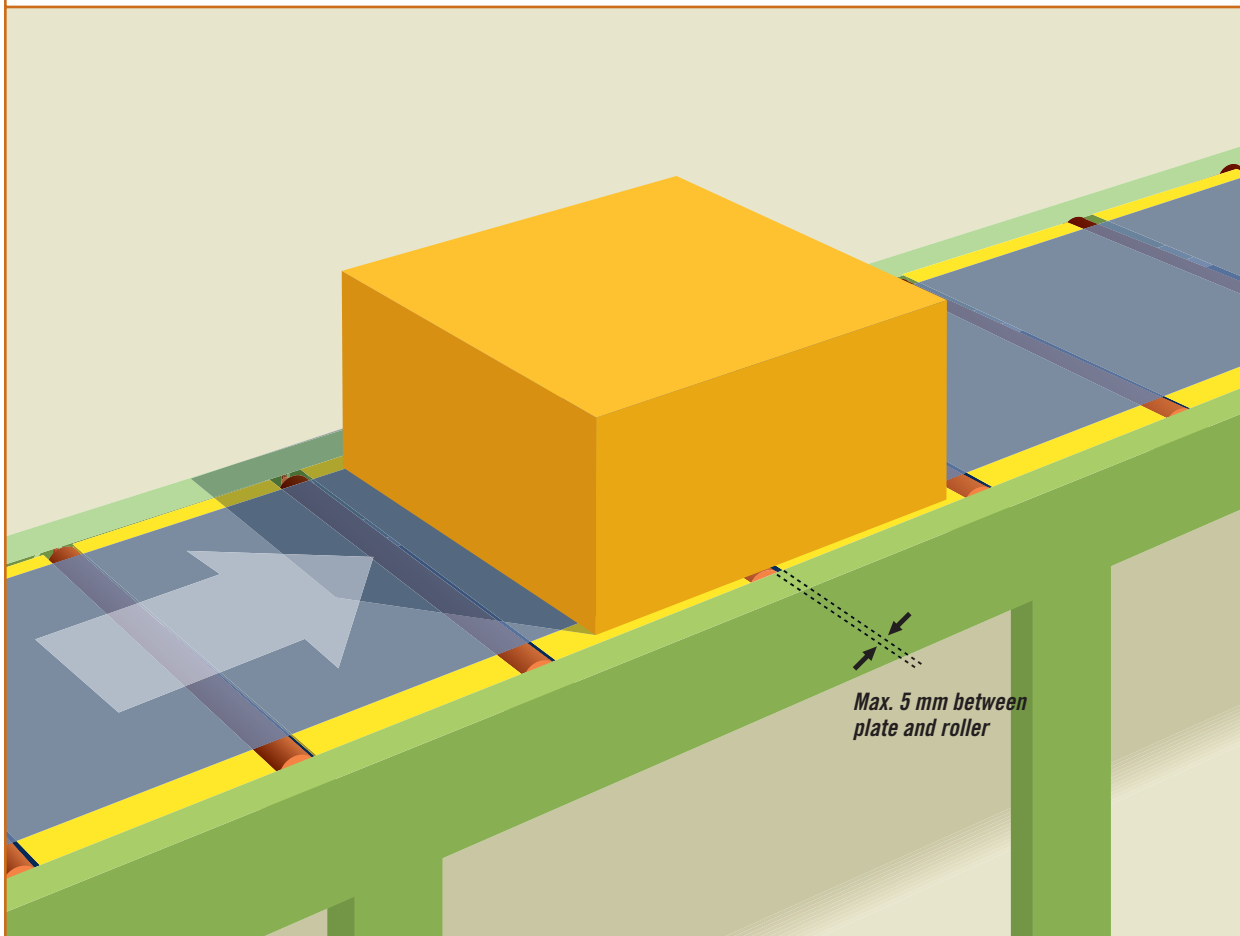


FIGURE 2-38 TYPICAL GUARD FOR INDIVIDUAL LOADS AND ROLLERS EXCEEDING BELT WIDTH

## 2.6.7 MOVING LOADS (continued)

### HAZARD

Loads falling from the belt

### POTENTIAL CONSEQUENCES

Impact with moving loads  
Crushed by falling loads

### PROTECTIVE MEASURES

(IF HAZARD IS LESS THAN 2700 MM FROM FLOOR OR WORKING PLATFORM)

Install protection plate, mesh netting or guiding rail to maintain individual loads on the conveyor and prevent them from falling off, in accordance with hazard assessment results.

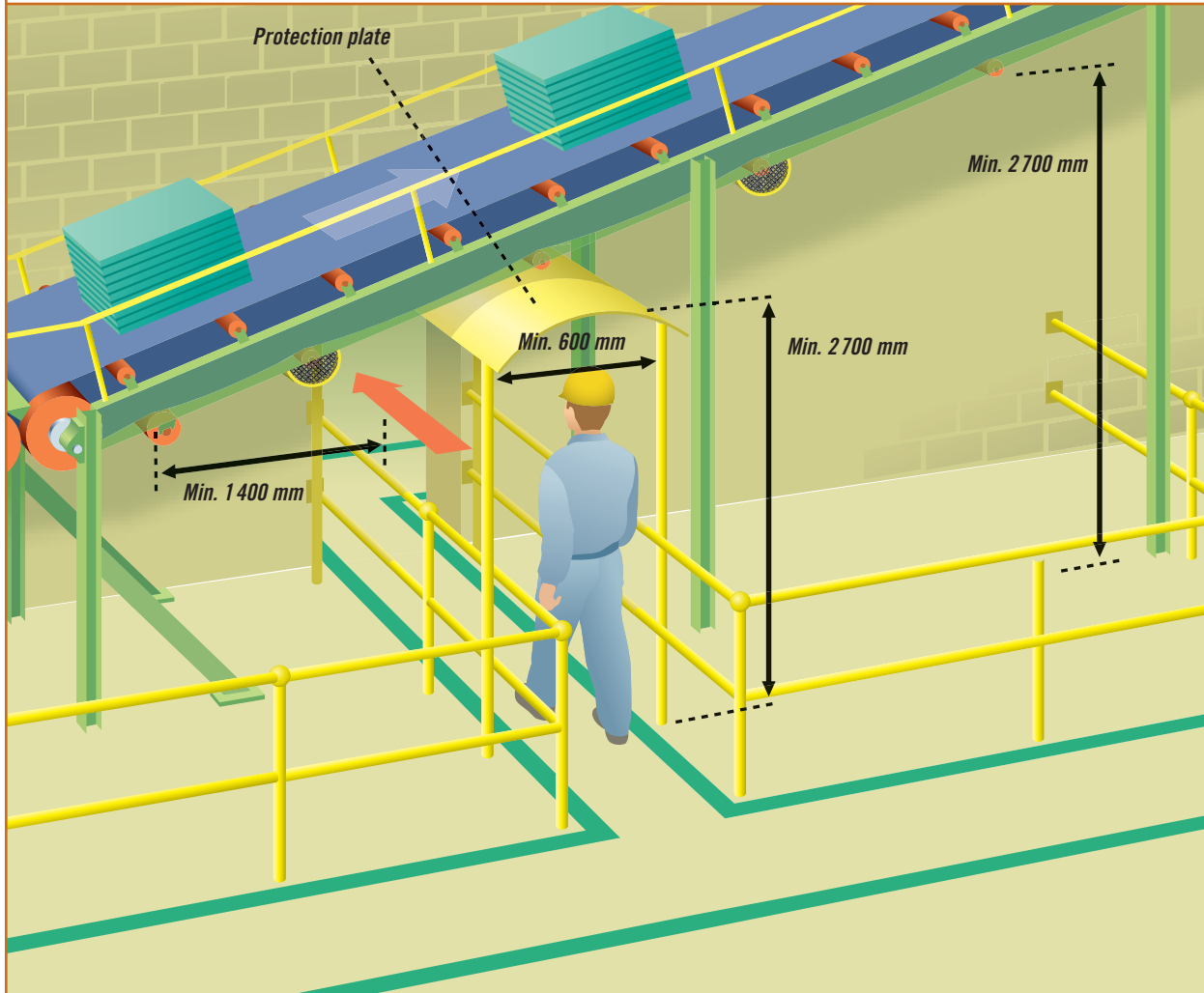


FIGURE 2-39 TYPICAL PROTECTIVE DEVICES FOR THROUGHWAYS

## 2.6.8 MOVING SUB-ASSEMBLIES

### HAZARDS

Pushers; bumpers; ejectors; sorters

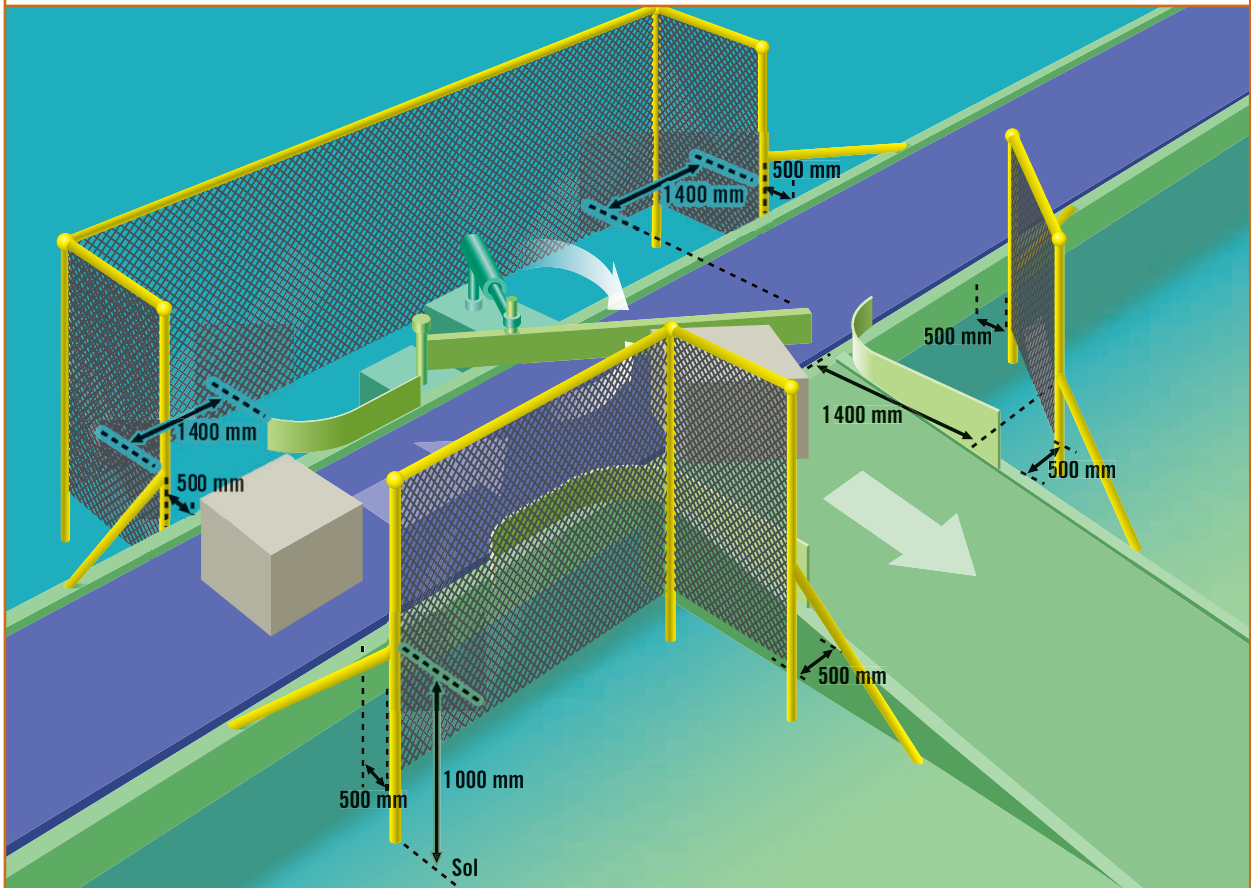
### POTENTIAL CONSEQUENCES

Crushing and shearing

### PROTECTIVE MEASURES

(IF HAZARD IS LESS THAN 2700 MM FROM FLOOR OR WORKING PLATFORM)

Install surrounding fixed or barrier guards.



**FIGURE 2-40** TYPICAL BARRIERS FOR EJECTORS

**Note:** Leave a safe distance between the load and the guard so as not to create a trapping hazard.

Minimum distances are:

If entire body can be drawn in: 500 mm

If arms can be drawn in: 120 mm

If legs can be drawn in: 180 mm

## 2.6.9 MOVEABLE CONVEYORS

### HAZARD

Vertical and/or horizontal movement

### POTENTIAL CONSEQUENCES

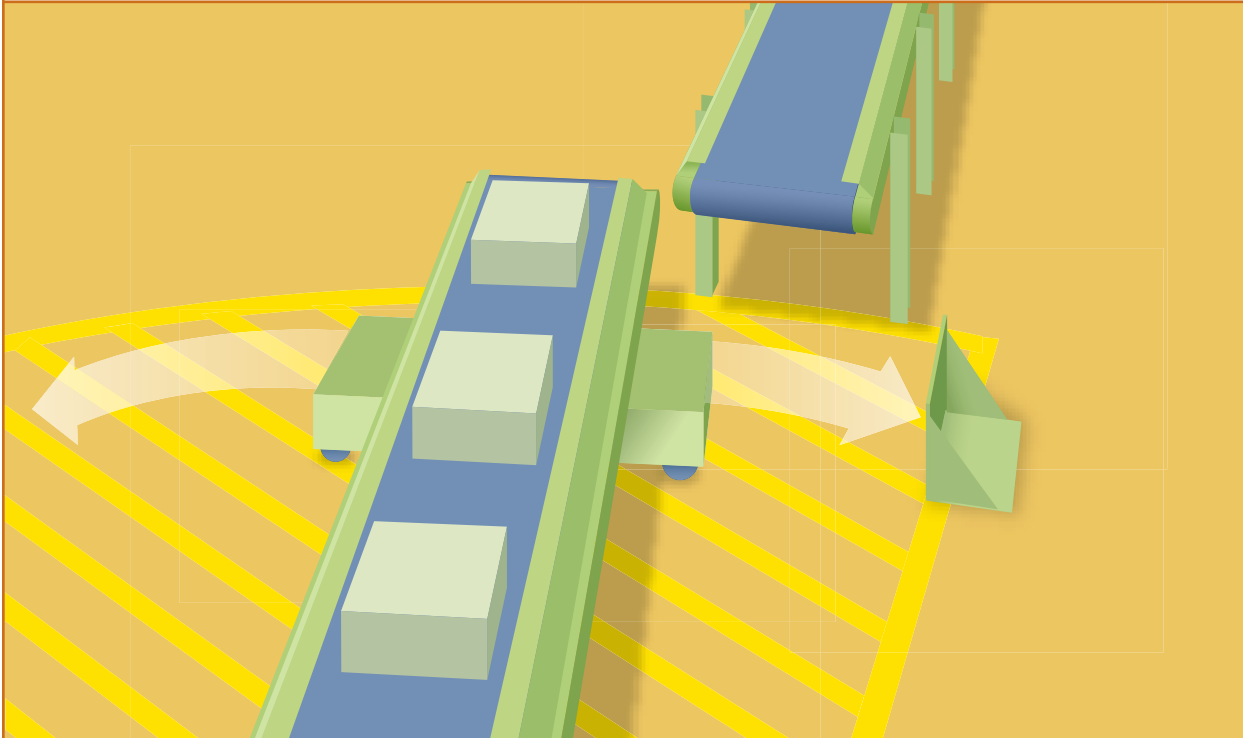
Crushing; entanglement; trapping

### PROTECTIVE MEASURES

(IF HAZARD IS LESS THAN 2700 MM FROM FLOOR OR WORKING PLATFORM)

In accordance with hazard assessment results: barrier guard, deterrent device or ground markings or signs to indicate the conveyor's operating area.

It is also possible to use electronic safety devices (surface detectors, etc.).



**FIGURE 2-41** MOVEABLE CONVEYOR

**Note:** The limits of the operating area must be considered before applying protective measures.

### 3.1 Hazards generated by poor ergonomic design

Equipment must be designed so that operators and other users need not assume constraining work postures, overexert themselves or carry out repetitive movements.

Control devices must be grouped near workstations to allow easy access for operators and other users. Such devices must be located outside danger zones so that activating them does not create hazards and so that workers do not have to enter the danger zones to access them. They must be positioned to prevent unexpected start-ups, and protected.

Every workstation or intervention area must be provided with adequate lighting for the nature of the work being done or for the nature of the work environment (refer to Part 12, Section 186 of the OH&S Code).

### 3.2 Heat-related hazards

Where conveyed products or any part of the equipment may cause burns, take the following precautions:

- ▶ Prevent contact with conveyed loads and hot (or cold) surfaces by using screens or fixed surrounding or barrier guards.
- ▶ Reduce the temperature of hot surfaces.

### 3.3 Electrical hazards

Conveyor electrical equipment must conform to the Canadian Electrical Code. Such equipment includes materials, accessories, devices, appliances, fasteners and other equipment used in the electrical power supply of a conveyor or in connection with a conveyor, including power disconnect devices.

In mines, electrical equipment must also conform to CAN/CSA Standard M-421-00, Use of electricity in mines, particularly those sections dealing with conveyors.

### 3.4 Fire and explosion hazards

The use of a conveyor can present a fire and explosion hazard. This hazard can be caused by the use of the conveyor itself or by the load (for example, combustible particles) the conveyor is carrying. Such hazards may be amplified by tunnels or by the stack effect. Preventive measures that may be implemented are described in Part 10, Fire and Explosion Hazards, of the OH&S Code. These preventive measures prohibit smoking, open flame and all other ignition sources. Other requirements, including classification of work sites in accordance with Canadian Electrical Code, are described in Part 10 of the OH&S Code. Refer also to CAN/CSA M-421-00, Use of Electricity in Mines (as applicable).

### 3.5 Inappropriate personal protective equipment and unsafe acts

Based on the hazard assessment of the work site, adequate personal protective equipment, including clothing, footwear and respirators, must be selected and worn by workers in accordance with Part 18, Personal Protective Equipment, of the OH&S Code.

Unsafe acts such as climbing over or under a conveyor, or stepping over, walking on or riding on a conveyor, must not be tolerated.



# 4

## SAFEGUARDS AGAINST CONTROL SYSTEM FAILURES OR MALFUNCTIONS

### 4.1 Start-Up

Start-up of equipment must require a voluntary action. Equipment start-up must be prevented in the following situations:

- ▶ during the closing of a guard
- ▶ during the actuation of an operation mode selector
- ▶ during the resetting of an emergency stop device
- ▶ during the resetting of a thermal protection device

In conveyors designed to supply loads to other conveyors, start-up of the supply conveyors must be linked with the receiving conveyors, using appropriate interlock devices. These devices must control and ensure sequential start-up, and must prevent conveyor overloading (whether the conveyor is fully loaded, or not in use).

For automatic or remote control start-up conveyors as well as for conveyors where the worker(s) cannot see the entire conveyor, a visible or audible warning device shall announce the starting of the conveyor (refer to Section 599 of the OH&S Code).

To prevent unexpected start-up, replace two-stable position (toggle) switches (start-stop) with self-powered or single-stable position control devices. These switches will bring the controls to an off-circuit mode (open contacts) should there be a power outage or conveyor failure.

### 4.2 Regular stop

There must be a device or method accessible to the worker(s) where equipment operations can be interrupted safely, while also ensuring that equipment cannot be unexpectedly restarted.

An all-stop switch is not designed to put an end to a recurring dangerous situation; this is the role of an emergency stop device. A stop command has priority over a start command.

### 4.3 Emergency stop device

The emergency stop device of a conveyor to which workers have access comprises several control devices located at the loading and unloading areas, as well as along the length of the conveyor. These devices must be easily visible and clearly identified, and must activate on a single action.



**FIGURE 2-42 STANDARD SYMBOL DESIGNATING  
FORCED TO BREAK CONTACT DEVICES**

Emergency stop devices must be installed at a height of between 0.6 and 1.7 meters from the floor. In addition, the device must have the following features:

- ▶ one or more push button switches
- ▶ one or more emergency stop pull-cords if required, along the full length of the conveyor (see Part 36, Mining, of the OH&S Code)
- ▶ a conveyor power-disconnect device, if the distance to the disconnect device is less than 10 metres from any conveyor access point

An emergency stop device must allow equipment to shut down in the safest possible way. This can be achieved by slowing down moving parts at an optimal rate, as follows:

- ▶ by an immediate interruption of power to the motors
- ▶ by a controlled stop (motors remain energized to bring the equipment down to a progressive stop and power is interrupted once the equipment has come to halt)

The resetting of an emergency stop device must not by itself cause the start-up of the machine unless the conveyor is a slow-moving type which workers can access safely. Start-up must be confirmed by a manual action (manual resetting).

The emergency stop command has priority over all other commands. Emergency stop devices must stop any upstream or downstream conveyors which may pose a safety risk to workers. The emergency stop device must not be used to bring the conveyor to an all-stop state. The emergency stop must not be used as a regular stop.

Remember that an emergency stop device does not replace appropriate protection devices. As well, emergency stop devices must not replace equipment lockout procedures during maintenance requiring access to danger zones.

## 4.4 Emergency stop pull-cords

If workers can access a conveyor in operation, it must be equipped with an emergency shutdown device along the full length of conveyor.

A sheathed metal strand cable shut-down device (pull-cord) must function as an emergency stop switch, whatever direction the cable is pulled in, or when the emergency stop switch is broken. A spring failure must also trigger an emergency stop.

A horizontal force of less than 125 N, when applied midway between two support rings and perpendicularly to the cable, must be sufficient to activate an emergency cable. Lateral movement of the cable (between the position while at rest and the activation point) must not exceed 300 mm. The cable must be able to resist a tension force 10 times greater than the tension required to activate the emergency shut-down switch, when such force is applied perpendicularly to the cable.

The cable must move freely within its supports, particularly at bends. Cables must not be twisted nor suffer the risk of being twisted during use. If a belt width is 800 mm or less, a single central cable may be used above the belt.

Maximum cable length and other characteristics must conform to manufacturers' recommendations (for support rings and pulley protection, freeze-up prevention, variation in length due to temperature changes, etc.)

Other appropriate cable devices, as determined by the hazard assessment, may be used where activation of the switch is done by pressure, compression, torsion or tension applied to the cable. This method is best suited to complex cable runs and to dusty or heavy-vibration environments.

# 5

## SAFEGUARDS WHILE PERFORMING MAINTENANCE

### 5.1 General principles

Equipment must be designed in such a way that maintenance adjustments, greasing, lubricating, temperature and/or vibration monitoring, cleaning, un-jamming, unclogging, etc.) can be done away from danger zones and without having to remove guards or other protective devices.

Section 310(2) of the Alberta Occupational Health and Safety Code 2009 states:

**310(2)** An employer must provide safeguards if a worker may accidentally, or through the work process, come into contact with

- a) moving parts of machinery or equipment,
- b) points of machinery or equipment at which material is cut, shaped or bored,
- c) surfaces with temperatures that may cause skin to freeze, burn or blister,
- d) energized electrical cables,
- e) debris, material or objects thrown from machinery or equipment,
- f) material being fed into or removed from process machinery or equipment,
- g) machinery or equipment that may be hazardous due to its operation, or
- h) any other hazard.

When it is necessary to access danger areas to carry out a maintenance task, safeguards must be implemented to ensure worker safety. An employer must ensure a hazard assessment is carried out, taking into consideration actual and potential hazards, and must ensure hazards, including hazardous energy, are controlled.

## 5.2 Lockout (controlling hazardous energy) procedures

Lockout/isolation procedures or controls should be an integral part of overall maintenance and operating procedures. Through the hazard/risk assessment process, the requirement for lockout(s)/isolation should be identified, evaluated and controlled.

Procedures for controlling hazardous energy should include (but are not limited to) the following:

- ▶ the equipment must be brought to a complete stop
- ▶ all sources of energy (electric, pneumatic, hydraulic, mechanical, thermal, chemical, radiation and gravity) must be disconnected
- ▶ all accumulated energy must be removed (by purging reservoirs, removing counter weights, unloading springs, etc.)
- ▶ personal lock(s) must be applied to each energy-isolating device
- ▶ the equipment must be tested to verify that it will not operate or move

**Note:** Legislative requirements for isolation of hazardous energy under the Alberta Occupational Health and Safety Code must be followed. These requirements are detailed in Part 15 of the OH&S Code.

## 5.3 Safeguards for maintenance within operating danger zones

At the core of injury and loss prevention is an understanding of workplace hazards and the associated risks. Hazard assessment is a systematic process of reviewing job methods and workplaces to identify, evaluate and prioritize hazards. Assessing hazards and understanding their nature and potential are critical to developing acceptable controls for avoiding incidents, injury and losses. Good solutions or controls are a result of adequate hazard assessments.

According to Section 10(1) of the Occupational Health and Safety Code, if emergency action is required to control or eliminate a hazard that is dangerous to the safety or health of workers:

- a) only those workers competent in correcting the condition, and the minimum number necessary to correct the condition, may be exposed to the hazard, and
- b) every reasonable effort must be made to control the hazard while the condition is being corrected.

**TABLE 2-4 SAFEGUARDS FOR MAINTENANCE ACTIVITIES  
HAZARD ASSESSMENT MUST BE DONE FOR EACH ACTIVITY.**

ACTIVITY	SAFEGUARDS
<b>Repairs; changing mechanical, electrical, hydraulic or pneumatic parts on conveyors or related accessories</b>	Lockout conveyor or related accessory.
<b>Belt replacement and splicing</b>	Lockout and application of a written safety procedure.
<b>Welding and cutting</b>	<p>Lockout if conveyor is located under the welding area, if practicable. Conveyor belts can be left running if hazard assessment determines no danger to workers.</p> <p>Lockout if the unprotected danger zone is less than 2700 mm from the work area.</p>
<b>Adjustment and fit</b>	<p>Authorized at all times, provided adjustment points (for example, scraper, drum and take-up system adjustment) are outside the danger zone.</p> <p>Lockout if adjustment points are inside the danger zone.</p> <p>Application of stipulations in the above section 5.3 of this guide.</p>
<b>Greasing and oiling (lubrication)</b>	<p>Authorized at all times where grease points are outside the danger zone.</p> <p>Lockout if grease points are inside the danger zone.</p>
<b>Housekeeping under and around conveyor; disposal of material recovered on the belt</b>	<p>Authorized at all times as long as the danger zone remains protected by a guard. Particular attention should be paid to the space under an inclined belt located less than 2700 mm from the floor (belt risk analysis).</p> <p><b>Reminder:</b> An opening 300 mm high, measured from the floor, will help in housekeeping.</p> <p>Lockout if the danger zone is not protected with a guard.</p> <p>Apply measures in the above section 5.3 of this guide, should the conveyor need to be operational.</p> <p><b>Note:</b> Should frequent removal of material accumulation from an operating conveyor be required, consider installing an operator workstation.</p>

**TABLE 2-4 SAFEGUARDS FOR MAINTENANCE ACTIVITIES (continued)  
HAZARD ASSESSMENT MUST BE DONE FOR EACH ACTIVITY.**

<p><b>Conveyor parts cleaning or maintenance (drums, rollers, chassis, etc.)</b></p>	<p>Lockout procedures apply.</p> <p>Operation authorized if housekeeping can be done:</p> <ul style="list-style-type: none"> <li>• with an automated (air or water) jet; or</li> <li>• according to the above section 5.3 of this guide.</li> </ul>
<p><b>Inspection</b></p>	<p>Visual and auditory inspection: permissible at all times as long as the worker remains outside the danger zone.</p> <p>If the conveyor remains operational while the worker enters to make contact with a machine part (for example, to measure vibrations), the point where the measurements are taken must not create a hazard to the worker.</p> <p>If the conveyor must remain operational while a guard is removed, apply measures described in the above section 5.3 of this guide.</p> <p>Lockout for all other cases (for example, mechanical free play measurements).</p>
<p><b>Unclogging, unjamming*</b></p>	<p>Lockout procedures apply.</p> <p>Apply measures described in the above section 5.3 of this guide should the conveyor need to be operational.</p>
<p><b>Maintenance activities not covered above</b></p>	<p>Lockout procedures apply at all times.</p>

\*Unclogging may create new specific hazards (such as the hazard of falling into a hopper, etc.), which must be analyzed before starting work.

All workers who work on or in the vicinity of conveyors must be informed of the hazards they may encounter, and must receive training in established preventive measures and work procedures. All safety-related procedures and instructions must be documented.

### 6.1 Worker training

Only competent and authorized workers must be allowed to start up, operate and interrupt the normal operation of a conveyor. Workers must be trained in:

- ▶ conveyor start-up
- ▶ normal shutdown and the use of emergency stop devices
- ▶ required checks for restarting a conveyor after an emergency shutdown or accidental stoppage
- ▶ proper loading procedures to prevent overload

### 6.2 Maintenance crew training

Assign only competent workers who have the technical skills to maintain conveyors. Assigned workers must be informed of the conditions under which various maintenance tasks are to be completed. Workers must be trained in lockout procedures.

When the removal of a guard or deterrent device is scheduled, workers must receive detailed instructions relative to their tasks, including procedures for installing and repositioning guards or deterrent devices. Supervisors and workers must check that guards and deterrent devices are back in place after maintenance activities are completed.

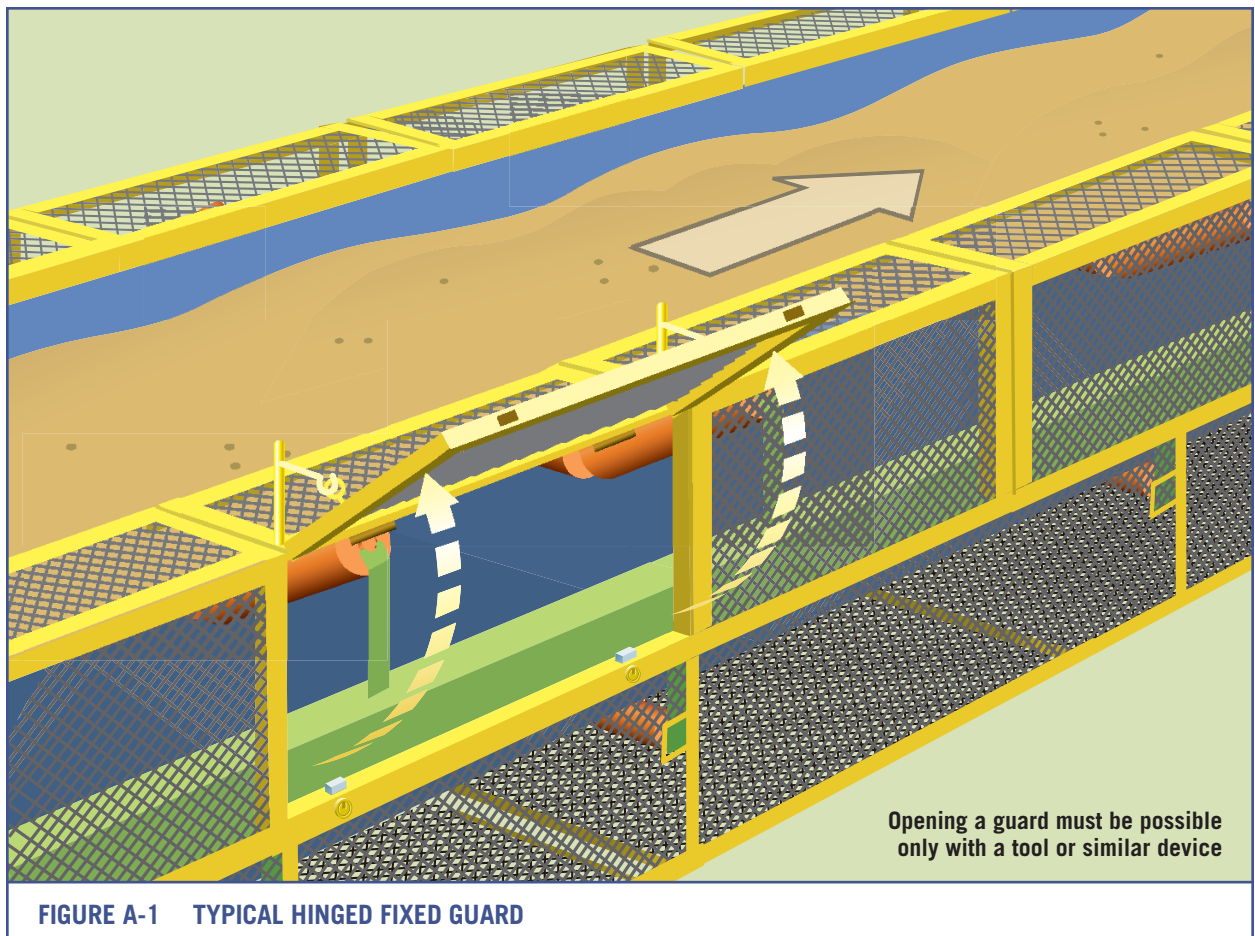
# APPENDICES

## APPENDIX A GUARD DESIGN

This appendix deals only with the design and ergonomics of guards. For information on types of guards and deterrent devices, application, dimensions and selection, see sub-sections 1 and 2 of Section II of this guide.

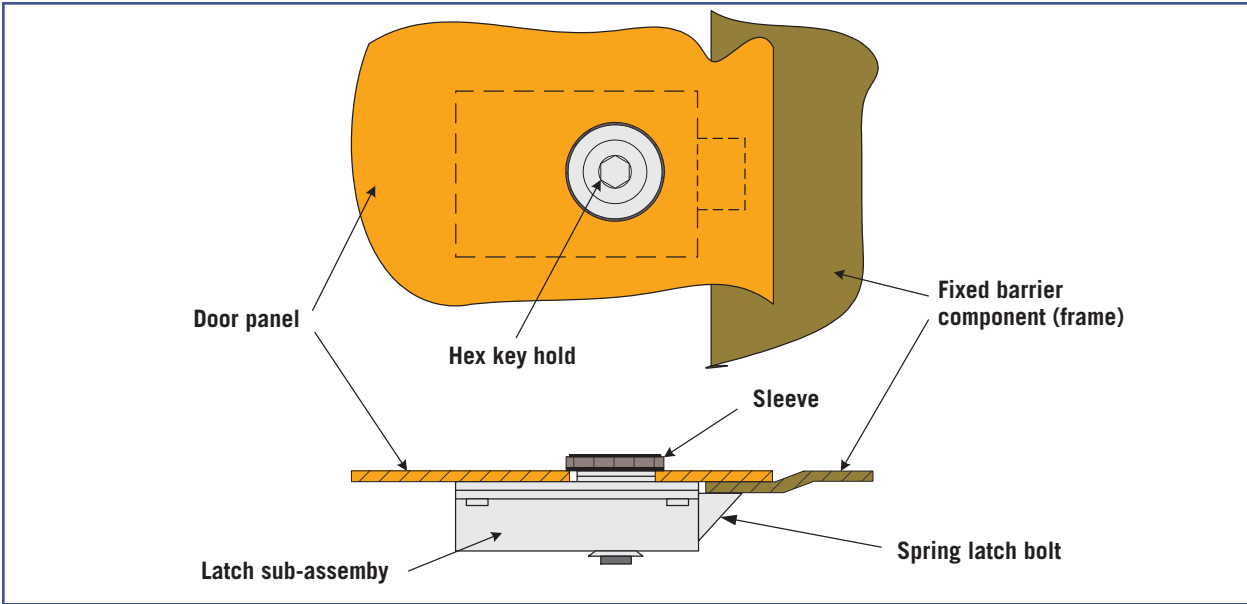
Guard construction and design must take into account all aspects of foreseeable use. Guards must not be the source of new hazards. For detailed information on the construction of guards, selection of materials and environmental considerations, please consult CSA Standard Z-432-04 Safeguarding of Machinery (Section 6.2.3 and Section 13).

It is important to consider ergonomic issues when designing guards. Correct application of ergonomic principles can enhance safety and reduce physical effort. Moveable guards should be designed so that the dimensions and weight of their parts allow for easy handling. To this end, articulated or hinged guards are preferred.



Guard removal and reinstallation must be quick and easy (for example, via quarter-turn keyed latches). Ideally, guards should be self-locking when closed.

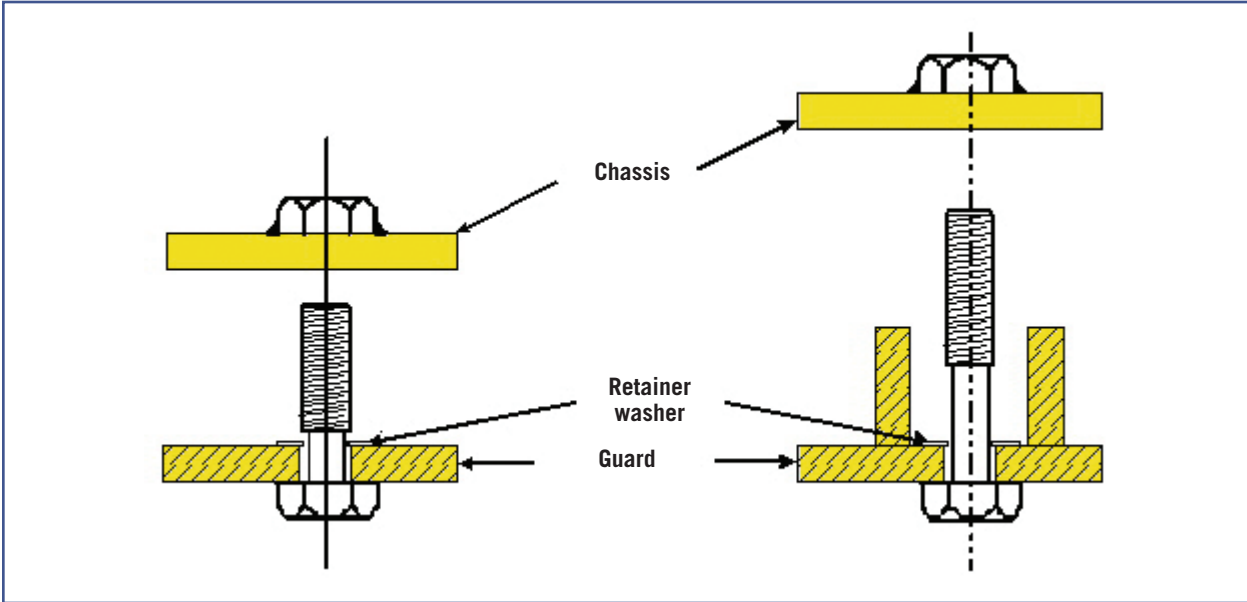




**FIGURE A-2 TYPICAL QUARTER-TURN KEYED SPRING LATCH**

In order to reduce as much as possible the number of items required to open guards, guard construction should be such that the protected components can be easily seen. Therefore, it is suggested that the screen of the guard be painted in a highly visible or reflective color. By painting hazardous machine components in bright, contrasting colors, attention is drawn to the danger zone when a guard is opened or removed.

Fasteners should remain permanently connected to the guards (“captive fasteners”). This precaution prevents the loss of fasteners and the need to replace them (see Figure A-3).



**FIGURE A-3 CAPTIVE FASTENERS**

# APPENDIX B CALCULATING THE REQUIRED DISTANCES FOR FIXED BARRIER GUARDS

(TABLE 2-2)

## Example 1 Calculating protector height (“b”)

### Initial data

Danger zone height (“a”) is 1500 mm and the horizontal distance from the guard to be installed (“c”) is 700 mm.

### Rationale

Always select a barrier ensuring the greatest level of security.

Since the danger height (“a”) of 1500 mm is not listed in Table 2-2, the values for the nearest upper height (1600 mm) and the nearest lower height (1400 mm) must be used in the calculation.

For each of these heights, locate the corresponding horizontal distance (700 mm) in column “c” of the table to find the appropriate protector height (“b”).

- ▶ When the danger zone height (“a”) is 1400 mm and the horizontal distance (“c”) is between 100 mm and 800 mm, the protector height (“b”) must be at least 1800 mm.
- ▶ When the danger zone height (“a”) is 1600 mm and the horizontal distance (“c”) is between 500 mm and 900 mm, the protector height (“b”) must be at least 1800 mm.

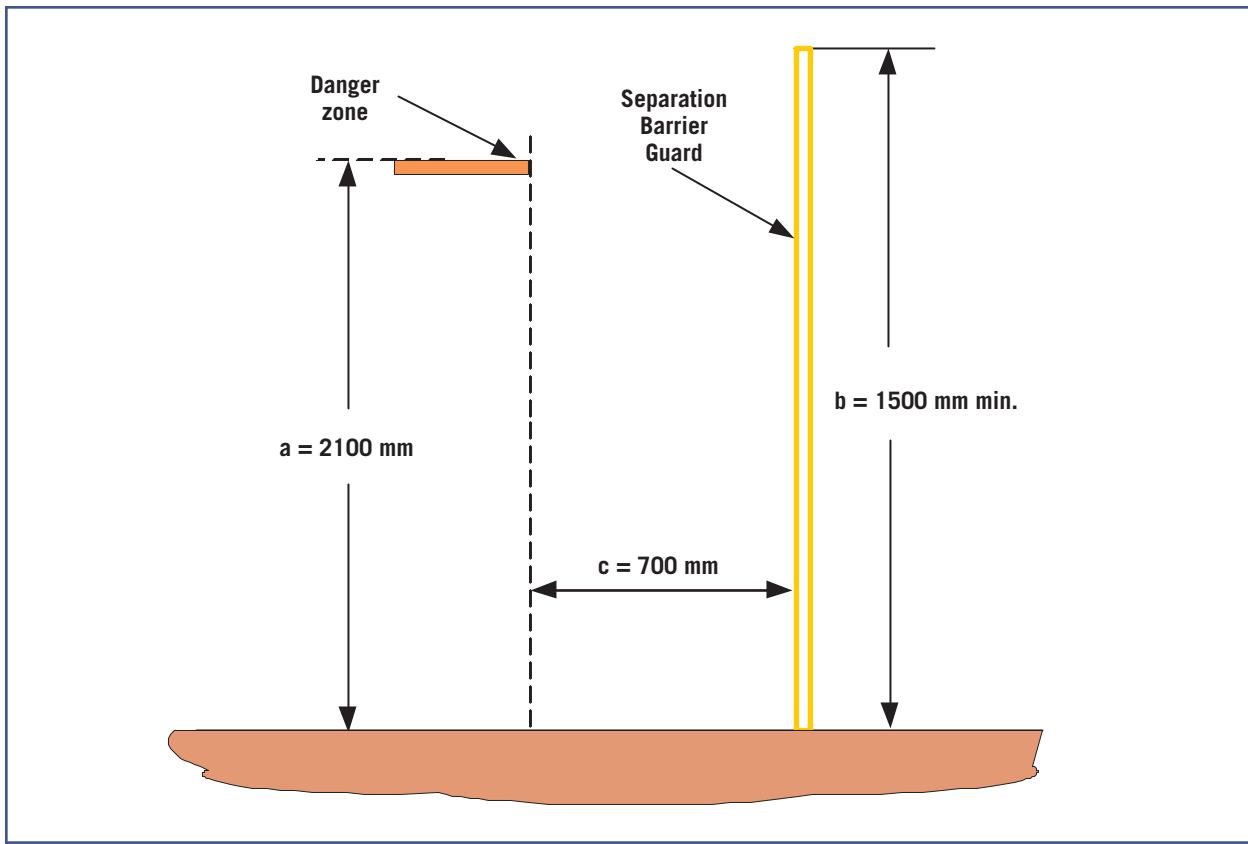
Finally, the selected protector must ensure the highest level of safety. In this example, both possibilities yield the same minimum height (“b”) of 1800 mm.

### Conclusion

The minimum height of the barrier guard must be 1800 mm when the danger zone height is 1500 mm and the horizontal distance is 700 mm (see Figure B-1).

**EXCERPT FROM TABLE 2-2 (EXAMPLE 1)**

Danger Zone Height “a” (mm)	Protective Structure Height “b” (mm)			
	1400	1600	1800	2000
	Horizontal Distance from Danger Zone “c” (mm)			
2400	100	100	100	100
2200	500	500	400	350
2000	700	600	500	350
1800	900	900	600	
1600	900	900	500	
1400	900	800	100	
1200	900	500		



**FIGURE B-1 SEPARATION BARRIER GUARD – EXAMPLE 1**

If the horizontal distance (“c”) between the danger zone and the planned guard is increased to more than 900 mm, then the height can be reduced to 1400 mm.

## Example 2 Calculating horizontal distance (“c”) between protector and danger zone

### Initial data

Protector height (“b”) is 1500 mm and the danger zone height (“a”) is 2100 mm.

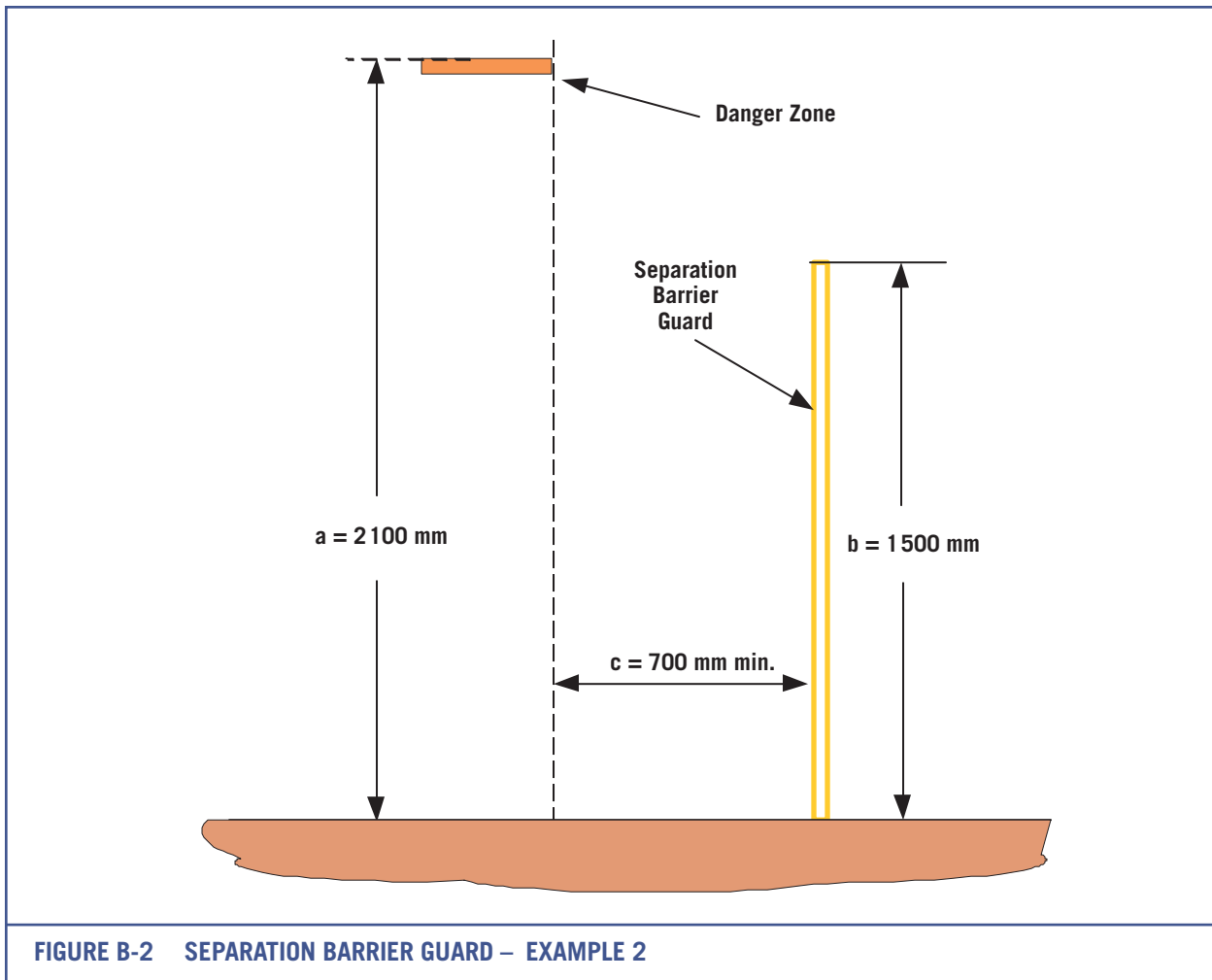
### Rationale

In Table 2-2, when considering the allowable distances (“c”) if the protector height (“b”) is between 1400 mm and 1600 mm, and the danger zone height (“a”) is between 2000 mm and 2200 mm, always select the distance that will yield the greatest level of safety.

### Conclusion

Minimum horizontal distance (“c”) between the danger zone and the protector must be 700 mm when the protector height (“b”) is 1500 mm and the danger zone height (“a”) is 2100 mm (see Figure 2-2).

EXCERPT FROM TABLE 2-2 (EXAMPLE 2)				
Danger Zone Height “a” (mm)	Protective Structure Height “b” (mm)			
	1400	1600	1800	2000
Horizontal Distance from Danger Zone “c” (mm)				
2400	100	100	100	100
2200	500	500	400	350
2000	700	600	500	350
1800	900	900	600	
1600	900	900	500	
1400	900	800	100	
1200	900	500		



**FIGURE B-2 SEPARATION BARRIER GUARD – EXAMPLE 2**

**Example 3 Calculating danger zone height (“a”)**

**Initial data**

Protector height (“b”) is 1700 mm and horizontal distance (“c”) from the danger zone is 550 mm.

**Rationale**

First, find the horizontal distance (“c”) for protector heights of 1600 mm and 1800 mm. The required distance (“c”) is greater for 1600 mm high protectors; this value must be used, since the safest distance is to be considered.

Then find the “c” values that are 550 mm or less. The danger zone can now be located with respect to the corresponding “a” values.

**Conclusion**

The danger zone height must be less than 1200 mm or more than 2200 mm when the protector height (“b”) is 1700 mm and the horizontal distance (“c”) separating them is 550 mm.

Where the horizontal distance (“c”) is not shown in Table 2-2, use the last value given in corresponding columns. For example, with a protector height (“b”) of 1600 mm and a danger zone height (“a”) of less than 1000 mm, the minimum separation distance (“c”) is 300 mm.

For danger zone heights greater than 2500 mm, a guard is not required.

**EXCERPT FROM TABLE 2-2 (EXAMPLE 3)**

Danger Zone Height “a” (mm)	Protective Structure Height “b” (mm)			
	1400	1600	1800	2000
Horizontal Distance from Danger Zone “c” (mm)				
2400	100	100	100	100
2200	500	500	400	350
2000	700	600	500	350
1800	900	900	600	
1600	900	900	500	
1400	900	800	100	
1200	900	500		
1000	900	300		
800	600			
600				
400				
200				
0				

## Explanations

### Reaching around

The safety distances of freely articulating body parts of persons, when reaching around edges in any position, are given in Table B-1.

The radius of movement about a fixed edge is determined by the reach of given body parts. The safety distances assigned should be respected as a minimum if the relevant body part is not to be allowed to reach a danger zone. Of special importance is the danger zone which can be reached when these body parts are introduced through slots.

When applying safety distances, it is to be assumed that the basic joint component of the relevant body part is in fixed contact with the edge. The safety distances apply only if it is ensured that further advance or penetration of the body part toward the hazard is excluded.

**TABLE B-1 SAFETY DISTANCES**

Limitation of movement	Safety distance $s_r$ , mm	Illustration
Limitation of movement only at shoulder and armpit	$\geq 915$	
Arm supported up to elbow	$\geq 550$	
Arm supported up to wrist	$\geq 230$	
Arm and hand supported up to knuckle joint	$\geq 130$	

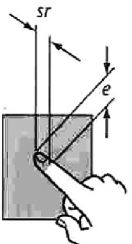
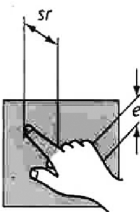
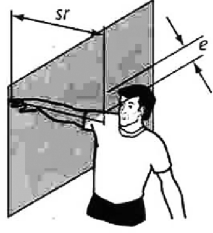
A = range of movement of the arm

\* Either the diameter of the round opening, or the side of a square opening, or the width of a slot opening.

## Reaching through regular openings

Safety distances (“sr”) for persons aged 14 and above are given in Table B-2. The dimensions of openings (“e”) correspond to the side of a square, the diameter of a round opening and the narrowest dimension of slot openings.

**TABLE B-2 SAFETY DISTANCES THROUGH REGULAR OPENINGS  
(SAFETY DISTANCE “SR” THROUGH REGULAR OPENING OF SIZE “E”)**

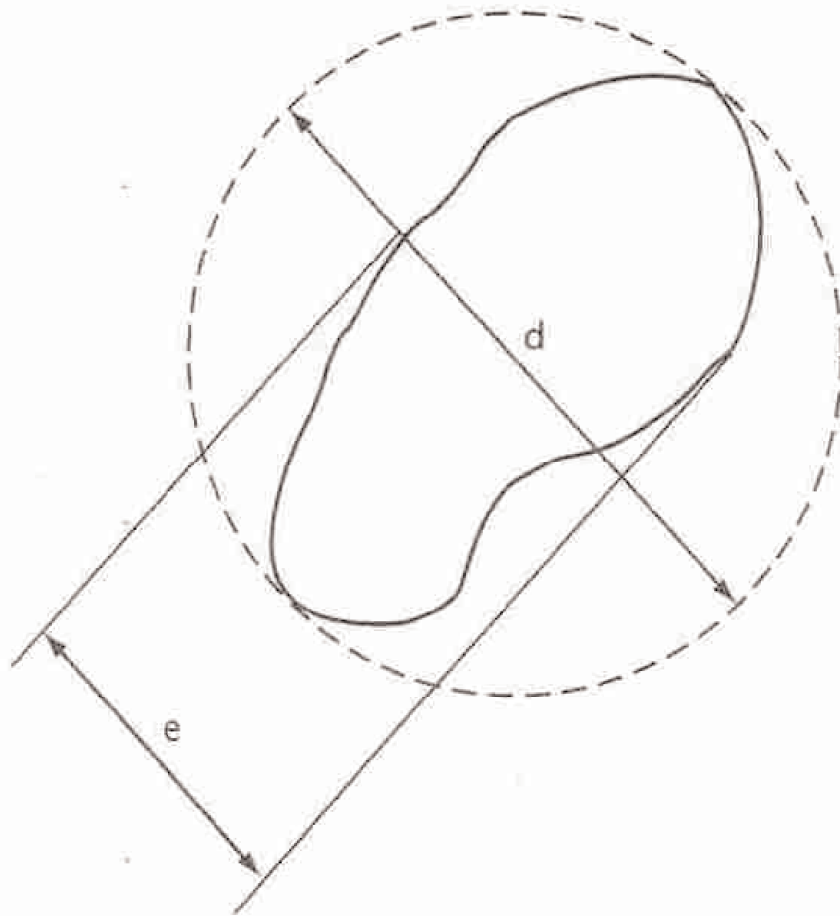
Part of body	Illustration	Opening	Safety distance, <i>sr</i>		
			Slot, mm	Square, mm	Round, mm
Fingertip		$e \leq 4$	$\geq 2$	$\geq 2$	$\geq 2$
		$4 < e \leq 6$	$\geq 10$	$\geq 5$	$\geq 5$
Finger up to knuckle joint or hand		$6 < e \leq 8$	$\geq 20$	$\geq 15$	$\geq 5$
		$8 < e \leq 10$	$\geq 80$	$\geq 25$	$\geq 20$
		$10 < e \leq 12$	$\geq 100$	$\geq 80$	$\geq 80$
		$12 < e \leq 20$	$\geq 120$	$\geq 120$	$\geq 120$
		$20 < e \leq 30$	$\geq 850^*$	$\geq 120$	$\geq 120$
Arm up to junction with shoulder		$30 < e \leq 40$	$\geq 850$	$\geq 200$	$\geq 120$
		$40 < e \leq 132$	$\geq 915$	$\geq 915$	$\geq 915$

\* If the length of the slot opening  $\leq 65$  mm, the thumb sill acts as a stop and the safety distance can be reduced to 200 mm.

## Openings of irregular shape

To choose a safety distance for an opening of irregular shape refer to Table B-2, using either the smallest aperture (“d”) that describes the opening, or the narrowest slot with parallel side (“e”) that will contain the opening (see Figure B-3). The smallest safety distance arrived at using this method may be used.





**FIGURE B-3 SAFETY DISTANCES FOR OPENINGS OF IRREGULAR SHAPE**

**Note 1:** Explanations in this Appendix are taken from CSA Z-432-04 “Safeguarding of Machinery.” For more information, refer to [www.csa.ca](http://www.csa.ca).

**Note 2:** Some of the values used in Table B-2 are taken from ISO 13852: 1996(F), “Safety of Machinery – Safety distances to prevent danger zones being reached by the upper limbs.”

## APPENDIX C ALBERTA LEGISLATION REFERENCE

Table C-1 lists applicable sections of the Alberta Occupational Health and Safety Act, Regulation and Code in regards to conveyor belts. Please note that other sections of the Code may also apply, depending on the work site.

TABLE C-1 APPLICABLE ALBERTA LEGISLATION		
STATUTES	APPLICABLE SECTIONS	
Occupational Health and Safety Act of Alberta (RSA 2000, May 24, 2006)	2	Obligation of Employers, Workers, etc.
	3	Prime Contractor
	35	Existence of Imminent Danger.
Occupational Health and Safety Regulation (Alberta Regulation 62/2003)	12	Equipment
	13	General Protection of Workers
	14	Duties of Workers
	15	Safety Training
Occupational Health and Safety Code 2009	7 – 9	Hazard Assessment, Elimination and Control
	12	Specifications and Certifications
	119	Safe Entry and Exit
	190	Skeleton Structures
Part 15 (Managing the Control of Hazardous Energy)	212 – 215	Managing the Control of Hazardous Energy
	228	Personal Protective Equipment
Part 22 (Safeguards)	310 – 322	Safeguards
	393	Working Alone
Part 36 (Mining)	598	Conveyors – Fire Resistance
	599	Conveyors – Stopping
	600	Conveyors – Travelling Room
	601	Conveyors – Combustible Dust
	602	Conveyors – Clearances
	603	Conveyors – Riding Conveyor Belts
	604	Conveyors – Examination
	605	Conveyors – Carbon Monoxide Monitors
	606	Conveyor Roadways
	660	Electric Conveyances
680	Conveyors in Underground Coal Mines	
698	Location	
742	Airborne Dust	

## APPENDIX D CONVEYOR SYSTEM CHECKLIST

Conveyors are useful for moving things around the workplace. However, moving machinery can cause serious injuries. This Conveyor System Safety Checklist provides a minimum checklist for ensuring safe conveyor belt operation. If any of the checklist boxes are marked with a NO, the employer must correct the deficiency immediately.

<b>CHECKLIST COMPLETION DATE</b>	<b>NEXT SCHEDULED REVIEW DATE</b> <i>(Annually or after a change to the workplace)</i>
YYYY / MMM / DD	YYYY / MMM / DD

<b>COMPANY INFORMATION</b>			
<b>Name</b>		<b>Branch or Location</b>	
<b>Address</b>		<b>Identification Number</b>	
<b>PERSONNEL INFORMATION (PERSON COMPLETING CHECKLIST)</b>			
<b>Name</b>		<b>Position</b>	<b>Contact Number</b>

<b>CONVEYOR SYSTEM SAFETY CHECKLIST</b>		
<b>TRAINING</b> Have operators received training, supervision and information about:		
• the correct method of starting and stopping the conveyor system?	Yes <input type="checkbox"/>	No <input type="checkbox"/>
• the hazards of the conveyor system in its normal operations?	Yes <input type="checkbox"/>	No <input type="checkbox"/>
• the hazards of being inattentive or not following safe work procedures?	Yes <input type="checkbox"/>	No <input type="checkbox"/>
• the purpose of guards?	Yes <input type="checkbox"/>	No <input type="checkbox"/>
<b>STARTING THE CONVEYOR</b> Before the conveyor system is started up, do you inspect to ensure that:		
• nobody is working on the conveyor system?	Yes <input type="checkbox"/>	No <input type="checkbox"/>
• access platforms are clear?	Yes <input type="checkbox"/>	No <input type="checkbox"/>
• guards are fitted?	Yes <input type="checkbox"/>	No <input type="checkbox"/>
• emergency stop switches are working and clearly marked?	Yes <input type="checkbox"/>	No <input type="checkbox"/>
• lanyards are fitted and working?	Yes <input type="checkbox"/>	No <input type="checkbox"/>
• lights are working and clean?	Yes <input type="checkbox"/>	No <input type="checkbox"/>
• start-up warning lights and signs are clearly visible?	Yes <input type="checkbox"/>	No <input type="checkbox"/>

<b>CONVEYOR SYSTEM SAFETY CHECKLIST (CONTINUED)</b>		
<b>STARTING THE CONVEYOR (CONTINUED)</b>		
<b>Before the conveyor system is started up, do you inspect to ensure that:</b>		
• start-up warning horns, bells or claxons are clearly audible?	Yes <input type="checkbox"/>	Yes <input type="checkbox"/>
• the area around the conveyor is clean?	Yes <input type="checkbox"/>	Yes <input type="checkbox"/>
<b>SAFE OPERATING PROCEDURES</b>		
Are all stop/start controls and emergency stop switches clearly marked?	Yes <input type="checkbox"/>	Yes <input type="checkbox"/>
Are workers aware of the locations of these controls and switches?	Yes <input type="checkbox"/>	Yes <input type="checkbox"/>
Are these controls within easy reach for workers?	Yes <input type="checkbox"/>	Yes <input type="checkbox"/>
Is the conveyor locked out or isolated before maintenance or clearing out are started?	Yes <input type="checkbox"/>	Yes <input type="checkbox"/>
Do operators wear appropriate, close-fitting clothing at all times?	Yes <input type="checkbox"/>	Yes <input type="checkbox"/>
Do operators keep hair controlled under caps at all times?	Yes <input type="checkbox"/>	Yes <input type="checkbox"/>
<b>GUARDS</b>		
Are guards in place to prevent access to all dangerous areas while the conveyor system is in operation?	Yes <input type="checkbox"/>	Yes <input type="checkbox"/>
Are guards either permanently or securely fixed to ensure they cannot be altered or detached without the aid of a tool or key?	Yes <input type="checkbox"/>	Yes <input type="checkbox"/>
If a fixed barrier is not practicable, and access to dangerous areas is required during operation, is an interlocked physical barrier used?	Yes <input type="checkbox"/>	Yes <input type="checkbox"/>
Are nip points guarded?	Yes <input type="checkbox"/>	Yes <input type="checkbox"/>
Are emergency stop devices in working condition?	Yes <input type="checkbox"/>	Yes <input type="checkbox"/>
Are emergency stop devices checked on a regular basis?	Yes <input type="checkbox"/>	Yes <input type="checkbox"/>
<b>THE MOVING CONVEYOR SYSTEM</b>		
<b>Do workers know:</b>		
• they must not walk under the moving conveyor system, unless it is guarded, to prevent spillage and/or entrapment by moving parts?	Yes <input type="checkbox"/>	Yes <input type="checkbox"/>
• they must not clean belts, pulleys, drums or troughs while the conveyor system is moving?	Yes <input type="checkbox"/>	Yes <input type="checkbox"/>
• they must not ride on or cross over the conveyor system?	Yes <input type="checkbox"/>	Yes <input type="checkbox"/>
• they must not carry out repairs or maintenance on the conveyor system while it is moving?	Yes <input type="checkbox"/>	Yes <input type="checkbox"/>

## APPENDIX E CONVEYOR-RELATED INCIDENTS IN ALBERTA

Table E-1 provides an overview of conveyor-related incidents that were reported to Alberta Workplace Health and Safety (WHS) from different sectors of industry. It is based on WHS data from November 2002 to May 2007.

TABLE E-1 CONVEYOR-RELATED INCIDENTS IN ALBERTA					
Industry	Fatality	Injury	Compliant	Imminent Danger	Recordable (%)
Manufacturing	0	2	5	6	16%
Coal	0	0	0	9	11%
Crushing	1	1	2	5	11%
Cement/Concrete	0	0	3	4	9%
Construction	1	0	2	2	6%
Stores	0	1	1	2	5%
Warehouse	0	2	1	1	5%
Bakery	0	1	2	0	4%
Compost	0	0	2	0	3%
Food	1	1	0	0	3%
Oil Sands	0	0	1	1	3%
Pulp & Paper	0	0	1	1	3%
Production	0	0	0	2	3%
Roofing	0	0	1	1	3%
Utility	0	0	2	0	3%
Carwash	0	0	1	0	1%
Distribution	0	0	0	1	1%
Drilling	0	1	0	0	1%
Forestry	0	1	0	0	1%
Foundry	0	0	0	1	1%
Greenhouses	0	1	0	0	1%
Hay Bales	0	0	1	0	1%
Laundry	0	0	0	1	1%
Meat Processing	0	0	1	0	1%
Petrochemical	0	1	0	0	1%
Recycle	0	0	1	0	1%
<b>Total</b>	<b>3</b>	<b>12</b>	<b>27</b>	<b>37</b>	

## REFERENCES

1. COMMISSION DE LA SANTÉ ET DE LA SÉCURITÉ DU TRAVAIL (CSST). *Sécurité des machines: phénomènes dangereux – situations dangereuses – événements dangereux – dommages*, Publication Number DC 900-337, 2002. (Machine Security: Hazards – Hazardous Situations – Hazardous Events – Damages).
2. COMMISSION DE LA SANTÉ ET DE LA SÉCURITÉ DU TRAVAIL (CSST). *Guide de prévention en milieu de travail: à l'intention de la petite et de la moyenne entreprise*, Publication Number DC 200-16082-2, 2000. (A Guide to Prevention in the Workplace for Small- and Medium-Sized Businesses).
3. QUÉBEC GOVERNMENT. *Regulations Respecting Occupational Health and Safety*, Decree 885-2001, 5-2.1, r.19.01, July 2001. Available from the CSST Document Center (English website under construction) (RJ-510071).
4. QUÉBEC GOVERNMENT. *Mines Occupational Health and Safety Regulations*, 5-2.1, r.19.01, June 2002. Available from the CSST Document Center (English website under construction) (RJ-510068).
5. QUÉBEC GOVERNMENT. *Safety Code for the Construction Industry*, 5-2.1, r.6, August 2001. Available from the CSST Document Center (English Website under construction) (RJ-530000).
6. CANADIAN STANDARDS ASSOCIATION. CSA Z432-94, *Machine Safety*, 1994. Available from the CSST Document Center (English website under construction) (NO-001570).
7. AFNOR. NF EN 620, *Continuous handling equipment and systems – Safety and EMC requirements for fixed belt conveyors for bulk materials*, 2002. Available from the CSST Document Center (English website under construction) (NO-003033).
8. BRITISH STANDARD INSTITUTE. BS 7300, *Code of Practice for Safeguarding of the Hazard Points on Troughed Belt Conveyors*, 1990. Available from the CSST Document Center (English website under construction) (NO-002753).
9. AFNOR. NF EN 294, *Sécurité des machines – Distances de sécurité pour empêcher l'atteinte des zones dangereuses par les membres supérieurs*, September 1992. Available from the CSST Document Center (English website under construction) (NO-120491). (Safety of machinery – Safety distances to prevent danger zones being reached by the upper limbs).
10. COMITÉ EUROPÉEN DE NORMALISATION. EN 811, *Sécurité des machines – Distances de sécurité pour empêcher l'atteinte des zones dangereuses par les membres inférieurs*, 1996. Available from the CSST Document Center (English website under construction) (NO-002202). (Safety of machinery – Safety distances to prevent danger zones being reached by the lower limbs).
11. AFNOR. NF EN 953 *Sécurité des machines – Protecteurs – Prescriptions générales pour la conception et la construction des protecteurs fixes et mobiles*, December 1997. Available from the CSST Document Center (English website under construction) (NO-002266). (Safety of machinery – Guards – General requirements for the design and construction of fixed and moveable guards).
12. INTERNATIONAL STANDARDS ORGANISATION. ISO 14119, *Sécurité des machines – Dispositifs de verrouillage associés à des protecteurs, principes de conception et de choix*, 1998. Available from the CSST Document Center (English website under construction) (NO-120715). (Safety of machinery – Interlocking devices associated with guards, principles for design and selection).

13. AFNOR. NF EN 292-1, *Sécurité des machines – Notions fondamentales, principes généraux de conception – partie 1: Terminologie de base, méthodologie*, December 1991. Available from the CSST Document Center (English website under construction) (NO-001500). (Machine Safety – Fundamental Notions and General Design Principles – Part 1: Basic Terminology and Methodology).
14. CENTRE TECHNIQUE DES INDUSTRIES MÉCANIQUES. *Équipements de manutention continue pour charges isolées – Mise en conformité, CETIM*, 1996. Available from the CSST Document Center (English website under construction) (MO-018973). (Continuous Individual Load Handling Equipment – Adherence Principles (CETIM)).
15. CANADIAN STANDARDS ASSOCIATION. CAN/CSA-M421-F00, *Use of Electricity in Mines*, 2000.
16. CANADIAN STANDARDS ASSOCIATION. CAN/CSA-M422-FM87, *Fire Resistance and Anti-Static Requirements for Conveyor Belts*, 2000.
17. INTERNATIONAL STANDARDS ORGANISATION. ISO 13850, *Safety of machinery. Emergency stop. Principles for design*, 1996. Available from the CSST Document Center (English website under construction) (NO-002190).
18. UNION TECHNIQUE DE L'ÉLECTRICITÉ (UTE). NF EN 60947-5-5, *Low-voltage switchgear and controlgear. Part 5-5: Control circuit devices and switching elements. Electrical emergency stop device with mechanical latching function*, April 1998. Available from the CSST Document Center (English website under construction) (NO-002622).
19. CAISSE RÉGIONALE D'ASSURANCE MALADIE D'ÎLE DE FRANCE (CRAMIF). *Installation et utilisation des transporteurs à bande dans les carrières, dispositions générales no 4*, 1994. Available from the CSST Document Center (English website under construction) (Belt Conveyor Installation and Operation for Quarries, General Rules #4).
20. INSTITUT NATIONAL DE RECHERCHE ET DE SÉCURITÉ (INRS). *Consignations et déconsignations*, ED 754, 1993. Available from the CSST Document Center (English website under construction) (MO-126203). (Holds and Releases).
21. AMERICAN NATIONAL STANDARDS INSTITUTE. ANSI Z244.1, *Safety Requirements for the Lock Out / Tag Out*, 1993.

# BIBLIOGRAPHY

## Conveyor Belts

- AFNOR. NF EN 1554, *Courroies transporteuses — Essais de frottement au tambour*, août 1999.
- AFNOR. NF EN 1724, *Courroies transporteuses légères — Méthodes d'essai pour la détermination du coefficient de frottement*, juin 1999.
- AFNOR. NF H 95-320, *Engins de manutention continue — Transporteurs à courroies destinés à être équipés d'un instrument de pesage totalisateur continu — Caractéristiques*, mai 1988.
- BRITISH STANDARD INSTITUTE. *Steel Cord Conveyor Belts — Adhesion Strength Test of the Cover to the Core Layer*, BS EN 28094: 1994, ISO 8094, 1984.
- CONVEYOR EQUIPMENT MANUFACTURERS ASSOCIATION. ANSI/CEMA 402-2002, *Conveyor Belts — Unit Handling Conveyors*, 2002.
- CONVEYOR EQUIPMENT MANUFACTURERS ASSOCIATION. ANSI/CEMA 502-2001, *Bulk Material Conveyor Belt Troughing and Return Idlers — Selection and Dimensions*, 2001.
- MINE SAFETY AND HEALTH ADMINISTRATION. *MSHA's Guide to Equipment Guarding*, OT 3, U.S. Department of Labor, 2000.
- NATIONAL SAFETY COUNCIL. *Conveyor Belt for Bulk Materials — Part 1: Equipment*, I-569, 1990.
- SUVA. *Liste de contrôle — Transporteurs à bande pour marchandises en vrac*, SUVAPro, réf. 67043.f, Suisse.

## Conveyors — General

- AMERICAN SOCIETY OF MECHANICAL ENGINEERS. *Safety Standard for Conveyors and Related Equipment*, ASME B20.1-2000 and addenda, 2000.
- AMERICAN SOCIETY OF SAFETY ENGINEERS. Safe use of conveyor, *Professional Safety*, vol. 38, no. 4, April 1993.
- COMITÉ EUROPÉEN DE NORMALISATION. EN 618, *Équipements et systèmes de manutention continue — Prescriptions de sécurité et de CEM pour les équipements de manutention mécanique des produits en vrac à l'exception des transporteurs fixes à courroie*, avril 2002.
- COMITÉ EUROPÉEN DE NORMALISATION. Projet définitif prEN 619, *Équipements et systèmes de manutention continue — Prescriptions de sécurité et de CEM pour les équipements de manutention mécanique des charges isolées*, octobre 2000.
- CONVEYOR EQUIPMENT MANUFACTURERS ASSOCIATION. ANSI/CEMA 102-2000, *Conveyor Terms and Definitions*, 2000.
- CONVEYOR EQUIPMENT MANUFACTURERS ASSOCIATION. ANSI/CEMA No. 401-2002, *Roller Conveyors — Non Powered* 2002.
- FYSON, R. Oliver. Conveying safety to the user, *Professional Engineering*, June 1990, pp. 30-31.



ONTARIO PRINTING AND IMAGING ASSOCIATION, INDUSTRIAL ACCIDENT PREVENTION ASSOCIATION AND WORKPLACE SAFETY INSURANCE BOARD. *Printing Industry Health and Safety Guide*, 2002.

S. D., << Manutention en vrac des solides — Technologies et critères de choix >>, *Informations Chimie*, no 326, mars 1991, pp. 148-153.

SCHULTZ, George A. Conveyor Safety Requirements when Using Older Equipment, American Society of Safety Engineers, *Professional Safety*, May 2001.

SCHULTZ, George A. *Conveyor Safety — Safety in the Design and Operation of Material Handling Systems*, American Society of Safety Engineers, 2000.

SCHULTZ, George A. *What a Safety Engineer Should Know About Conveyor Safety*, ASSE's 2001 Professional Development Conference, June 2001.

SMANDYCH, R. Susan et al. Dust Control for Material Handling Operations: a Systematic Approach, *American Industrial Hygiene Association Journal*, Vol. 58, No. 2, February 1998, pp. 139-146.

SLJOKAS, Jouko. Evaluation of the Effect of Safety Regulation, Case Studies in Press and Conveyor Regulations, *Safety Science*, Vol. 16, No. 3-4, 1993, pp. 307-324.

## Machine Safety

AFNOR. NF EN 292-2, *Sécurité des machines — Notions fondamentales, principes généraux de conception — partie 2: Principes et spécifications techniques*, décembre 1991.

AFNOR. NF EN 292-2/A1, *Sécurité des machines — Notions fondamentales, principes généraux de conception — partie 2: Principes et spécifications techniques*, juin 1995.

AFNOR. NF EN 349, *Sécurité des machines — Écartements minimaux pour prévenir les risques d'écrasement de parties du corps humain*, septembre 1993.

AFNOR. NF EN 894-2, *Sécurité des machines — Spécifications ergonomiques pour la conception des dispositifs de signalisation et des organes de service — partie 2: dispositifs de signalisation*, avril 1997.

AFNOR. NF EN 954-1, *Sécurité des machines — Parties des systèmes de commande relatives à la sécurité — partie 1: Principes généraux de conception*, février 1997.

AFNOR. NF EN 999, *Positionnement des équipements de protection en fonction de la vitesse d'approche des parties du corps*, décembre 1998.

AFNOR. NF EN 1037, *Sécurité des machines — Prévention de la marche intempestive*, mars 1996.

AFNOR. NF EN 1050, *Sécurité des machines — Principes pour l'appréciation du risque*, janvier 1997.

AFNOR. NF EN 1088, *Sécurité des machines — Dispositifs de verrouillage associés à des protecteurs, Principes de conception et de choix*, juin 1996.

AMERICAN NATIONAL STANDARDS INSTITUTE. ANSI/RIA R15.06-1999, *American National Standard for Industrial Robots and Robot Systems — Safety Requirements*, June 1999.

AMERICAN SOCIETY OF MECHANICAL ENGINEERS. ASME B15.1-2000, *Safety Standard for Mechanical Power Transmission Apparatus*, 2000.

BRITISH STANDARD INSTITUTE. PD 5304-2000, *Safe Use of Machinery*, 2000.

COMMISSION DE LA SANTÉ ET DE LA SÉCURITÉ DU TRAVAIL (CSST) ET L'INSTITUT DE RECHERCHE ROBERT-SAUVÉ EN SANTÉ ET EN SÉCURITÉ DU TRAVAIL (IRSST). *Amélioration de la sécurité des machines par l'utilisation des dispositifs de protection*, publication no DC 100-1313.

COMMISSION DE LA SANTÉ ET DE LA SÉCURITÉ DU TRAVAIL (CSST) ET L'INSTITUT DE RECHERCHE ROBERT-SAUVÉ EN SANTÉ ET EN SÉCURITÉ DU TRAVAIL (IRSST). *Mode d'emploi du sécurimètre*, publication no DC 500-191, 2002.

GORIS, Anne-Marie. << Les dangers des points rentrant >>, *Travail et sécurité*, no 586-587, juillet-août 1999, p. 36.

LUGDUNUM, Bernard. << Contrat de prévention — Concassage en douceur à la carrière Roffat >>, *Travail et sécurité*, no 585, juin 1999.

LUPIN, Henri et Jacques MARSOT. *Sécurité des machines et des équipements de travail — Moyens de protection contre les risques mécaniques*, INRS, ED 807, 2000.

MAUGE, Michel. *Machines et équipements de travail — Mise en conformité*, INRS, ED 770, 1998.

ORGANISATION INTERNATIONALE DE NORMALISATION. ISO 13853, *Sécurité des machines — Distances de sécurité pour empêcher l'atteinte des zones dangereuses par les membres inférieurs*, 1998.

PAQUES, Joseph-Jean et Réal BOURBONNIÈRE. *Formation en sécurité des machines: appréciation et réduction du risque*, IRSST, septembre 2002.

